

Review on gravity compensation by mechanism synthesis

Purav P. Parekh^{*2}, Krishan Kumar Gotewal¹, Manohar Stephen M.¹,
Kaushal Bhavsar²

¹Remote Handling and Robotics Technology Development Division, Institute for Plasma Research, Gandhinagar, India

²Department of Mechanical Engineering, LDRP – Institute of Technology and Research, Gandhinagar, India

Presented in International Conference on Advancements and Futuristic Trends in Mechanical and Materials Engineering held at Indian Institute of Technology Ropar (IITR), Rupnagar, during December 5-7, 2019.

ABSTRACT

KEYWORDS

Counter balance,
Compensation,
Non-Linear Spring,
Pulley and Gear.

An articulated robot spends a very high amount of energy carrying the weight of its own arm while working against gravity, which results in an increase in size actuators, which also increases the expense and weight of the system. Thus, a high amount of actuated power is utilized to compensate for the gravitational torques. Gravitational Torques are generated due to the mass of the robot arm and inertia of the payload. This torques severely affect the dynamic performance of the robot and the ability to withstand external forces. The presented review paper gives a detailed idea on various methods to compensate the gravitational torque, in which the gravity effect is compensated fully by a mechanical structure that reduces the actuator size.

1. Introduction

Advancement in robotic lead to gravity compensation mechanism. Gravity compensation mechanism has many applications in day-to-day life like in rehabilitation of human-arm; leg, rib, etc., exoskeleton, remote handling operations, robotics-arm, in various appliances like equipose lamp, dental bracket, balancing a projector.

Gravity compensation has an important role in remote handling and robotics. In this paper, we will describe the various application of gravity compensation and its development in remote handling and robotics. Remote handling has been developed for the applications as a substitute of human efforts in complicated areas as well as places where human cannot work like fusion reactors etc. The use of gravity compensation mechanism is to reduce vibrations in master/slave technology in Remote handling. The negative effect of gravity torque on the actuator is one of the significant problems in robotics.

Gravity compensation is the most commonly used techniques used in robotics to maintain equilibrium through the system. There are

many robotics devices operated under very low speed. Generally, gravitational torque produced by the weight of the links is very high than dynamic torques. Therefore, gravity compensation is beneficial in maintaining equilibrium in the system and reducing actuator load. In this paper, various typical gravity compensation solutions are presented and their effectiveness is measured.

2. Gravity Compensation

A system is only considered as fully gravity compensated if the weight of the links does not produce any forces or torques at the actuator in any configuration over gravity field. Gravity Compensation is classified by the way of energy consumption. Active Gravity Compensation mechanism uses an extra actuator to equilibrate gravity loading or it is also achieved by increasing the size of the primary actuator. Hence, it requires an external mean of energy.

However, it provides an active mean of compensation in every configuration of work. If we use a primary actuator to compensate the gravity loading then it will degrade the dynamic performance of the system. Hence due to drastic consumption of energy comes the birth of passive compensation. In a passive compensation mechanism, techniques like counter weight

*Corresponding author,
E-mail: purav_parekh@yahoo.com

balancing, using restoring force of linear or nonlinear spring, using non-circular pulley, etc. The reason why passive gravity compensation is most widely used in robotics now a days is that it does not require any external mean of energy, therefore, this mechanism becomes less heavy. (Chheta, 2017)

2.1. *Passive gravity compensation by counterweight mechanism*

Counterweight balancing is one of the most widely used approaches in passive gravity compensation (Endo, 2010). Here an extra weight is mounted on the robot at a specific distance by which the weight of the links is partially compensated. In this case of counter weight balancing, the center of mass of link coincides the joint and thus improves the performance of the arm.

The main flaws of this mechanism are that the extra weight added to counter the gravity effect increases the overall weight of the system as well as it requires bigger actuator, which is not acceptable. Hence, spring balancing was taken into consideration.

2.2. *Passive gravity compensation by linear-spring*

As discussed above, the drawbacks of the counterweight mechanism lead to passive compensation by spring.

V. Arakelian explained gravity balancing by zero free length spring by directly connecting it to a manipulator, as shown in Fig. 3. Zero free length spring means a specially designed spring which would exert zero force if its length is zero. But in actual zero length, spring is not possible, because a coil spring is unable to contract to zero length as at one point the coil will touch with each other and it cannot be further contracted. A better explanation of zero length spring is explained in Fig. 3. As shown in Fig. 3 the one end of the spring is mounted on the wall and the other end is pinned to the link at point A. Considering the length of the link s and length of spring l . (Vigen, 2016)

As we know that potential energy of the system remains constant if the gravitational torque is completely balanced by the elastic force of spring. i.e.

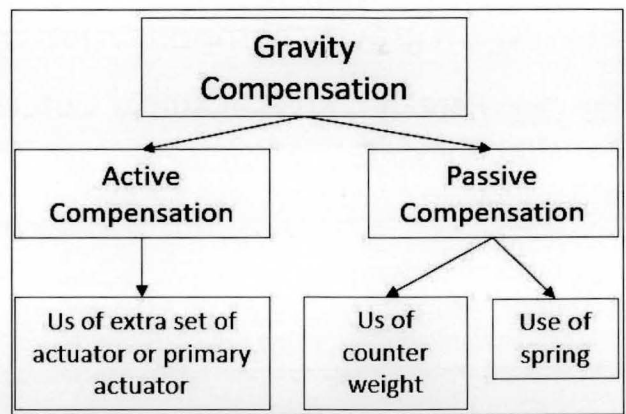

Fig. 1. Classification of Gravity Compensation (Chheta, 2017).

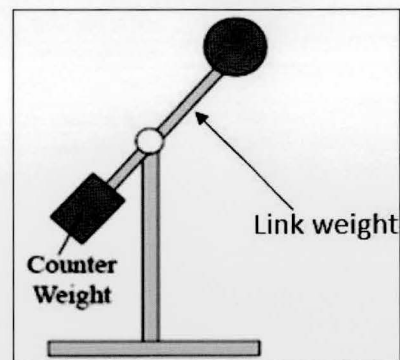

Fig. 2. Counterweight mechanism.(Endo, 2010).

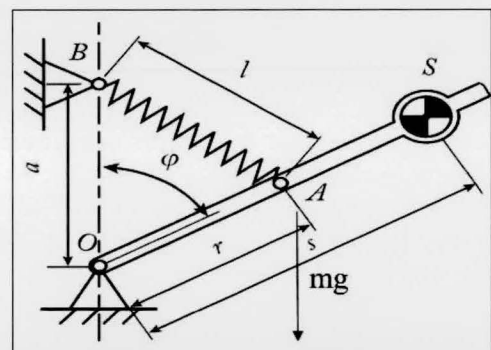

Fig. 3. Gravity compensation by zero free length Spring. (Vigen, 2016).

$$F_{sp} = \frac{mgs l}{ar} \quad (1)$$

Where m is the mass of the link, ϕ is the angle between the vertical axis and the link, $F_{sp} = k(l - l_0) + f$ is the elastic force of the spring, f is the initial force of the spring, where l_0 is the initial length of the spring, k is the stiffness of the spring, a is the distance of mounting point of spring to the fulcrum point, r is the distance for point O to point A on link [4]. It is observed from the equation (1) that fully gravity compensation

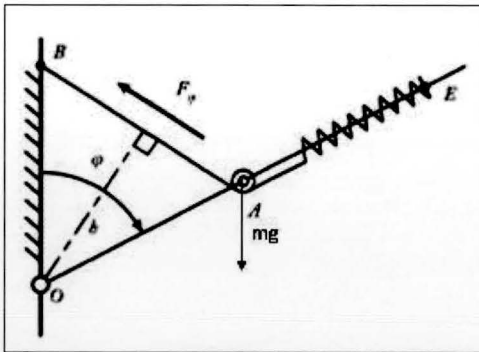

Fig. 4. Gravity compensation by cable, pulley and non-zero free length Spring. (Vigen, 2016).

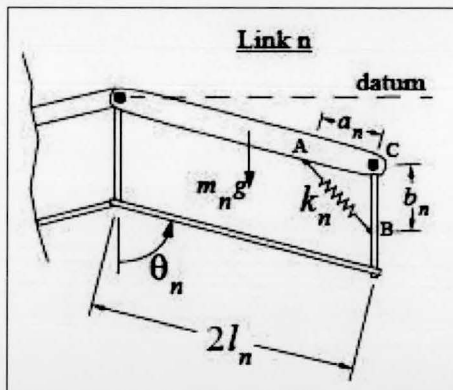

Fig. 5. Gravity compensation by N-links. (Rahman,, 1995).

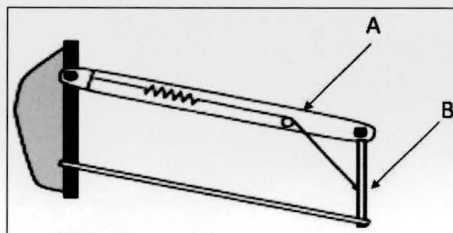

Fig. 6. Gravity compensation by pulley and spring. (Rahman,, 1995).

can be achieved only when $f = kl_0$ i.e. when zero spring length is used. But, if $f \neq kl_0$ i.e. non-zero free length spring is used, so here partial gravity compensation is achieved.

Due to the achievement of only partial gravity compensation using non-zero free length spring, compensation using a pulley and a cable is proposed by V. Arakelian [4]. By adding cable and pulley, fully gravity compensation can be achieved although by using non-zero free length spring. This is explained by an example of a rotating link as shown in Fig-4. The equation of gravity compensation is rewritten from equation (1) as:

$$mgs \sin \phi = F_{sp}h \tag{2}$$

It is similar to the (1) when length l of the spring is equal to l_{AB} . But in this case $l_{AB} = l - l_0$ is considered due to the cable and $h = (ar/l_{AB}) \sin \phi$, therefore by solving equation (2) we get $mgs = kar$, when $f = 0$. Hence, the rotating link can be balanced without using Zero free length spring. This is a solution for only a single link mechanism. (Vigen, 2016)

T Rahman et al., proposed a solution for gravity compensation of one link arm and generalized for N-Link arms. The method of conservation of energy was applied to balance the system. The methodology introduced by them use of kinematics and linear spring is considered to generate non-linear restoring force to counteract gravitational moment. In the N- link solution, each link has two DOF, one about a vertical axis, which is not affected by gravity, and the other about a horizontal axis as shown in Fig-5. (Rahman,, 1995)

The kinetic energy of this system is zero and potential energy is constant for all configuration, as the system is static. Assuming that the supporting links are massless, the potential energy of the last link is given by:

$$PE = -m_n g l_n \cos \theta_n + (K_n/2) (x_n - x_0)^2 \tag{3}$$

Here X is the X_0 is the unstretched length of the spring. Considering the stiffness K of the spring constant, X_0 has to be zero. This is only possible if the spring is placed outside the line AB , as shown in Fig. 6.

Hence, the generalized equation for t - link is given below

$$K_t = (g / (a_t b_t)) \left(m_t l_t + \sum_{s=t+1}^n 2m_s l_s \right) \tag{4}$$

Y. Hung et al., presented a new mechanism for gravity compensation by introducing gear-based balancer. They proposed integration of a planetary gear train and inverted cardan gear mechanism. In this gear-based mechanism, rotatory motion is converted into a straight-line motion by using a pair of gear. (Hung, 2017)

As shown in Fig. 7a, the mechanism is composed of a planetary gear, ring gear, and an arm. Here the pitch diameter of the ring gear in double than that of a planetary gear and point

a on the ring gear will generate straight-line motion along line PQ in Fig. 7a. Due to the straight-line motion, the idea of using cardan gear mechanism in gravity compensation mechanism has developed. Here the gear arm is selected as a frame and the ring gear is the input link attached to the payload, thus making an inverted Cardan gear mechanism. Hence, when payload arm rotates with an angle θ , the ring gear will rotate with θ as well and point A moving along line PQ generates displacement relation i.e.

$$s(\theta) = 2r \sin \theta \tag{5}$$

Here in figure-6b, s is displacement of point A w.r.t. the ring gear and r is the radius of the sun gear. Now if a tensile spring is installed between point P and A, and the elongation of the spring is equal to the length of the straight-line motion, the elastic potential energy U_k of the spring is given by:

$$U_k = \frac{ks^2}{2} = 2kr^2 \sin^2 \theta \tag{6}$$

The mass center of all links do not move during motion in the inverted cardan gear mechanism, so the balancing condition is not affected by the gravitational effect of the gear's masses.

3. Applications of Passive Gravity Compensation In Industry

3.1. Applications in Tokamak

Gravity compensation act a very important role in Remote handling equipment used for inspection in tokamak reactors.

D. Keller et al., worked on the development of ITER relevant advance robotic system for fusion reactor. Here they presented the demonstration of Remote Handling Equipment (RHE) used in Tore Supra Tokamak in order to have an in-vessels inspection as shown in Fig. 8. (Keller, 2008)

The RHE consist of 9.5 meters of cantilever length with 6 modules weighing 300kg and a payload of 10kg. Hence, it imposes a huge amount of gravitational torque on joints, which has to be counter balanced for maintaining equilibrium. So in order to lift this heavy equipment, the design of the system must be an optimist. Therefore, gravity compensation was introduced in this

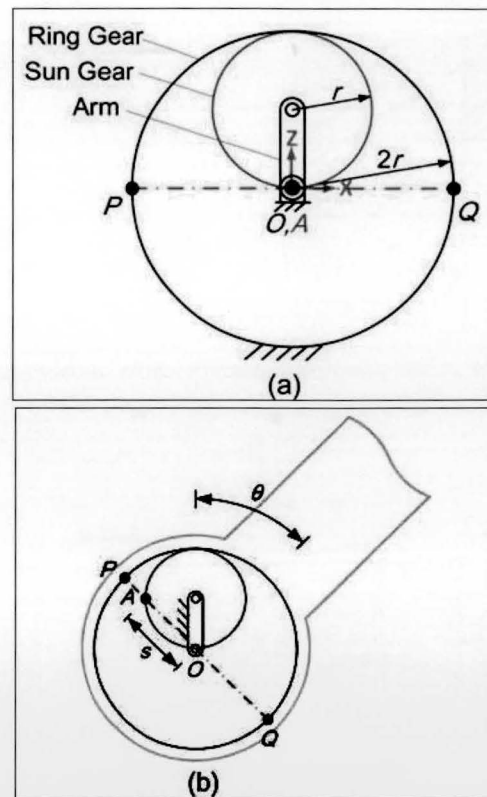

Fig. 7. Cardan gear-based gravity compensation. (Hung, 2017).

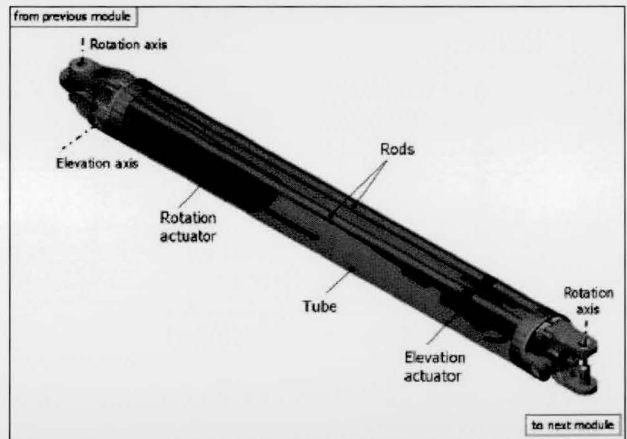

Fig. 8. Remote handling equipment module. (Keller, 2008).

case to balance the gravitational torque. Here parallelogram mechanism elastic force of spring is used to reduce gravity loading.

Here the parallelogram plays an important role in reducing the gravity loading over joints by keeping the head of the module always vertical for a given configuration. Now by using the elastic energy of the spring as shown in Fig. 8, we can reduce more gravity effect and hence reducing the size of the actuator and better dynamic performance of the equipment.

3.2. Applications in Industries

one of the best applications of gravity compensation is at passive handling manipulator and industrial robot for material handling, as shown in Fig. 10, like lifting various heavy weighted components or lifting fragile parts or working on the body in the air.

Kruger et al., presented a conventional method of gravity compensation by using counterweight balancing mechanism. They constructed a simple method, which used parallelogram links to lift the load at one end and the other end is grounded at which weight for compensation is attached. The spring and pulley mechanism is mounted to give compensation for various positions, as shown in Fig. 11. (Krüger, 2006)

This mechanism has a very complex structure due to both using spring and weight. So, Y. Rogério et al. in their novel introduced a new compensation method by using gas spring and lever-based material handling the device. They constructed an intelligent assist devices (IAD) which combine the advantages of a robot and a conventional device. (Rogério, 2010)

Here as shown in Fig. 12, lever lifts the load of material and is balanced by the gas spring at the other end lever which is fulcrum joined at a specific length from lift arm to load arm. The gas spring creates a force by a pneumatic piston mounted on it. Hence, the moment created by spring force balances the moment by the load. However, the issue here is that this mechanism is balanced for some specific configuration so the correction mechanism is applied here. A PLC (programmable logic controller) is the brain of this system. According to the requirement of the force, the mechanism will self-align by a screw which is rotated by a motor. Hence, as an outcome, we can have a self-aligning material handling device which can be cheaper than the older once as wells as can be run automatically.

3.3. Medical applications

various medical surgical machines require gravity compensation to reduce vibrations, as they cause fatal accidents. In addition, gravity compensation is used in orthosis devices for human organ rehabilitation.

F. Agrawal describes the applications of gravity compensation in human organ rehabilitation [10].

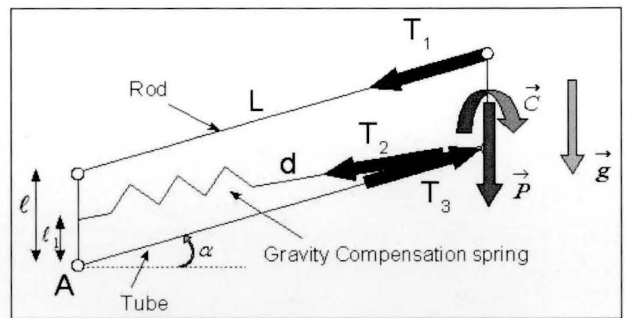

Fig. 9. Gravity forces repartition in the parallelogram structure. (Keller, 2008).

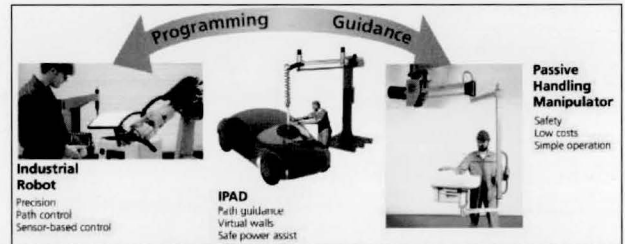

Fig. 10. Passively manipulated handling. (Krüger, 2006).

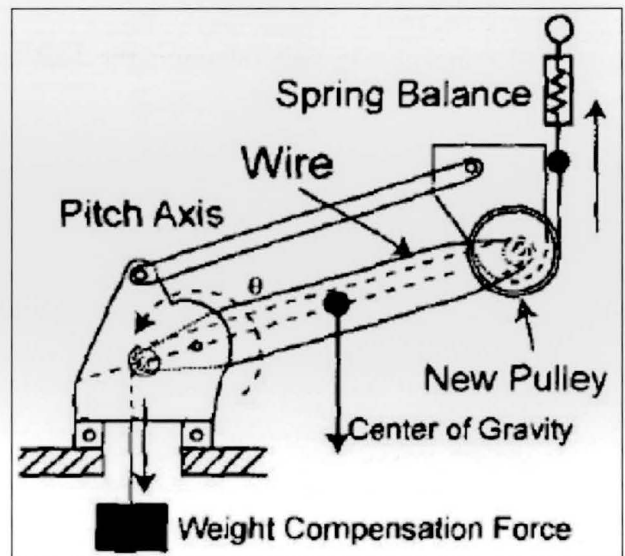

Fig. 11. Counterweight balancing for material handling. (Krüger, 2006).

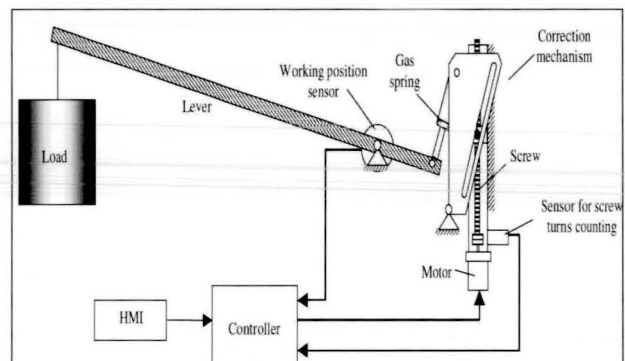

Fig. 12. Lever mechanism with the gas spring and the correction mechanism. (Rogério, 2010).

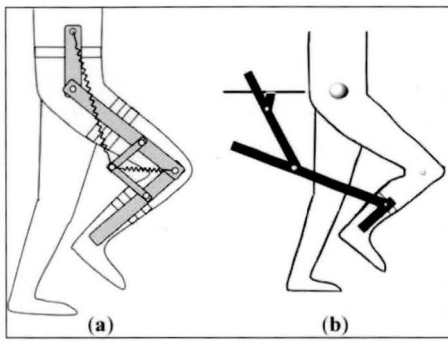

Fig. 13. (a) The open loop leg orthosis (b) The closed loop leg orthosis. (Fattah, 2011).

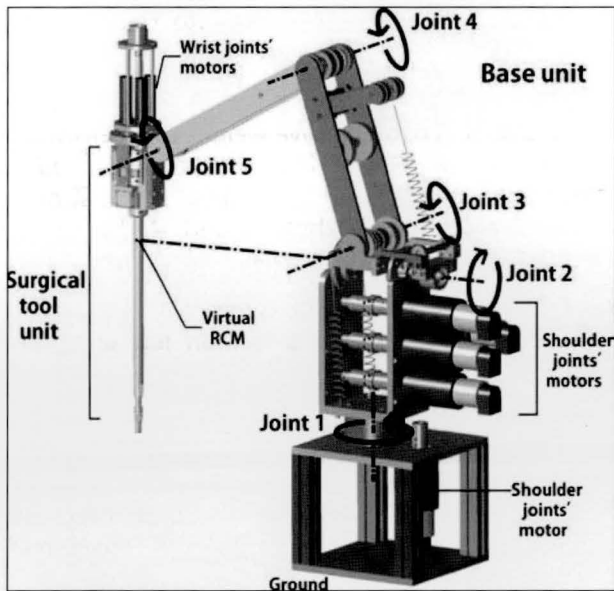

Fig. 14. Design of a surgical manipulator. (Kim, 2013).

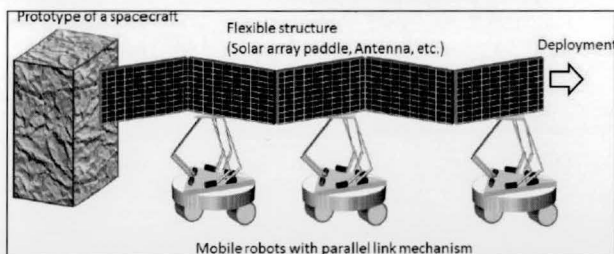

Fig. 15. Mobile robot with parallel links. (Tsujiata, 2014).

As shown in Fig. 13(a, b), is a leg orthosis; open loop and closed loop. (Fattah, 2011)

It was designed for reliving partial weight of the leg for peoples suffering from muscles weakness. Fig. 13(a) shows a spring-based passive leg orthosis designed to assist and train the patients suffering from muscle weakness by relieving the partial weight of the leg.

A hybrid strategy was adopted in the design to obtain the weight relief by designing an auxiliary parallelogram for leg segments such

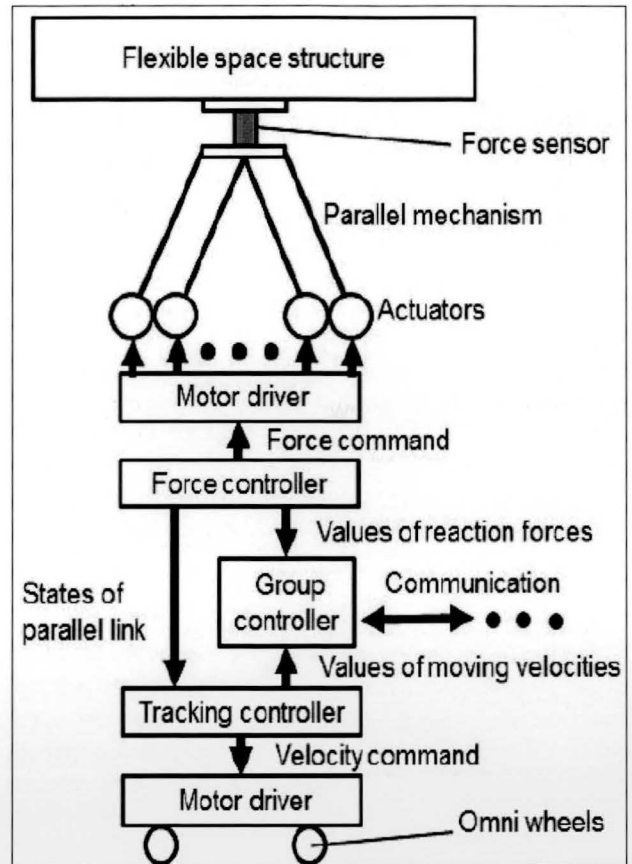

Fig. 16. Structure of Stewart-platform. (Tsujiata, 2014).

that the combined center of mass (COM) of the mechanism and the leg segment is at one of the corners of the auxiliary parallelogram. Due to the issues related to the alignment of the joints, he proposed a modified design in which the exoskeleton is connected to an only single point on leg calf, instead of mounting the whole skeleton on the leg as shown in Fig. 13(b).

Ki. Kim et al., presented a surgical manipulator with the ability to perform open surgery as well as Laparoscopy surgery. The main application of this kind of surgical manipulator is for providing surgical expertise in rural areas as well as on battlefield where a doctor has no reach. Therefore, a doctor can remotely operate this device from a far distance and the manipulator can work as a master-slave. Fig. 14 shows the conceptual design of surgical manipulator. (Kim, 2013)

Here they used spring and pulley/cam mechanism to compensate the weight of the surgical manipulator. A parallelogram is formed by the way spring is attached with cable and pulley. Hence, fully gravity compensation is achieved for all configuration of the arm.

3.4. Space applications

The use of gravity compensation in the aeronautical industry is to have testing of the various machines in zero gravity, as creating zero gravity by vacuum on earth is quite difficult as well as expensive. K. Tsujita et al. proposed a system for testing the prototypes of the flexible parts of a spacecraft by using mobile robots. Here they used multiple Stewart platform robots to lift the weight of the flexible part and create a zero-gravity atmosphere for the flexible part, as shown in Fig. 15. (Tsujita, 2014)

The robot used here has six DOF of parallel links to guide and support the flexible structure by compensating the gravity effect and creating a frictionless environment. The robots are moving on an Omni-directional platform. The structure of the Stewart platform robot is explained in Fig. 16.

4. Conclusion

It is concluded from various survey described above that the passive gravity compensation can drastically improve the dynamic performance of the robot. Passive gravity compensation does not require an external mean of energy, so it reduces the energy requirements of the system. In addition, the usage of spring-based gravity compensation reduces the size of the actuator, which is quite economical. The use of a counterweight mechanism is not much feasible in Remote handling applications, as it increases the overall weight of the system. Gravity compensation by cable, pulley, and spring can be more efficiently developed for counter balancing in In-Vessels inspection robots used in fusion application.

Acknowledgment

Thanks to Institute for Plasma Research, Gandhinagar for allowing me to carry out this review and their full-hearted co-operation in providing all the necessary data and detailed guidance during this review work.

This paper is a revised and expanded version of an article entitled, 'Review on Gravity Compensation by Mechanism Synthesis' presented at '7th International Conference on Advancements and Futuristic Trends in Mechanical and Materials Engineering' held at Indian Institute of Technology Ropar, Rupnagar, India during December 5-7, 2019.

Disclaimer

The views and opinions expressed herein do not necessarily reflect those of the Institute for Plasma Research, Gandhinagar.

References

1. Chheta, Y., Joshi, R., Gotewal, K.K., & Manoahstephen, M. (2017, January). *Review on passive gravity compensation. In Proceedings of the International Conference on Electronics, Communication and Aerospace Technology, ICECA 2017, 184–189.* Institute of Electrical and Electronics Engineers Inc.
2. Endo, G., Yamada, H., Yajima, A., Ogata, M., & Hirose, S. (2010). *Passive weight compensation mechanism with a non-circular pulley and a spring.* In Proceedings - IEEE International Conference on Robotics and Automation, 3843–3848.
3. Fattah, A., Hajizadeh, K., & Agrawal, S.K. (2011). Gravity balancing of a human leg using an external orthosis. *Journal of Medical Devices, Transactions of the ASME, 5*(1).
4. Hung, Y.C., & Kuo, C.H. (2017). Novel one-DoF gravity balancer based on cardan gear mechanism. *In Mechanisms and Machine Science, 43, 261–268.* Kluwer Academic Publishers.
5. Delphine, K., Jean-Pierre, F., & Y.P. (2008). *ITER Relevant Robot for Remote Handling: On the Road to Operation on Tore Supra.* In Advances in Service Robotics. InTech.
6. Kim, K.Y., Song, H.S., Suh, J.W., & Lee, J.J. (2013). Novel surgical manipulator with workspace-conversion ability for telesurgery. *IEEE/ASME Transactions on Mechatronics.*
7. Krüger, J., Bernhardt, R., & Surdilovic, D. (2006). Intelligent assist systems for flexible assembly. *CIRP Annals - Manufacturing Technology, 55*(1), 29–32.
8. Rahman, T., Ramanathan, R., Seliktar, R., & Harwin, W. (1995). Simple technique to passively gravity-balance articulated mechanisms. *Journal of Mechanical Design, Transactions of the ASME, 117*(4), 655–657.
9. Rogerio, Y., Andre, H., & Oswaldo, H. (2010). Load Balancer With Automatic Lifting Force Compensation. *ABCM Symposium Series in Mechatronics, 4, 580-589.*
10. Shigematsu, H., Tsujita, K., & Kishimoto,

N. (2014). *Development of a gravity compensation system for the prototype test of spacecraft by using mobile type multi robots*. In MOVIC 2014 - 12th International Conference on Motion and Vibration

Control. Japan Society of Mechanical Engineers.

11. Arakelian, V. (2016). Gravity compensation in robotics. *Advanced Robotics*, 30(2), 79–96. Taylor & Francis.



Mr. Purav P. Parekh is currently pursuing a Bachelor of Engineering in Mechanical Engineering from LDRP – Institute of Technology and Research, Gandhinagar, India. He also worked as Research Intern at the Institute for Plasma Research for 6 months. He has presented a paper at ‘7th International Conference on Advancements and Futuristic Trends in Mechanical and Materials Engineering’ held at the Indian Institute of Technology Ropar, Rupnagar, India during December 5-7, 2019. He has also pursued internship at BITS Pillani Hyderabad on Compressive Automobile Development Internship in December 2018.

Mr. Krishan Kumar Gotewal is currently working at the Institute for Plasma Research, Bhat, Gandhinagar at a position of Scientific Officer – SF. He is the division head of the Remote Handling and Robotics Technology Development Division (RHRTD) at the Institute for Plasma Research. He has completed his B.Tech. in Mechanical from A.M.U. Aligarh, U.P. India in June 1999. He has a working experience of 19 years in the field of mechanical engineering. He has 4 publications in peer reviewed journals and conference proceedings. He has guided five M. Tech. Projects. He was deputed to ITER Organization, France (Nov 2007 to June-2014) through IPR. He was awarded an award for excellent performance by ITER, France in 2012.



Mr. Manoah Stephen currently works at the Institute for Plasma Research, Gandhinagar at a position of Scientific Officer – E. He works as a Mechanical Engineer In the Remote Handling and Robotics Technology Development Division (RHRTD). He is currently pursuing M.Sc. Engineering (Mechanical) by Research from Homi Bhabha National Institute, India. He has work experience of 9 years. He has 2 publications in peer-reviewed journals and 13 publications in peer-reviewed conference proceedings. He has guided three M. Tech. Projects. He has handled various international as well as domestic projects in Fusion Reactor Studies Division, Cryopump Division and RHRTD Division.

Dr. Kaushal Bhavsar pursued his Ph.D. in Mechanical Engineering from KSV University. He also works as Lecturer at LDRP-ITR, Gandhinagar. Mr. Kaushal completed his master's in the field of mechanical engineering with a specialization in computer integrated manufacturing from Ganpat University. He completed his bachelor in Mechanical Engineering from KSV University. Mr. Kaushal has 8 years of teaching experience. His research interests are in Industrial Design, Quality Engineering, Robotics & AI. He has published more than 20 papers in national and international conferences and journals. His has good hands on ANSYS, CREO, SOLID EDGE, NX11, AutoCAD, MATLAB. He has also worked with ISRO on various projects.

