

Cyber Physical Systems and Resilience in Micro grid

Anurag S.D. Rai¹, Dr. Anil Kurchania¹, Dr. C.S. Rajeshwari², Reeta Pawar¹

¹Dept of EEE, Rabindranath Tagore University, Raisen (M.P.) India.

²Dept of EEE, NITTTR, Bhopal (M.P.) India.

ABSTRACT

In present era power systems architecture is now reconfigured and deregulated. Resilience of power systems is property to keep it within security limits and stable condition, which in present interconnected and complex system is major concern. Due to this advancement in automation in each stage Bi-directional power flow between utility and end-users' are now common aspect. As the Distributed Renewable Energy (DRE) Sources in present scenario is mostly affordable technology by end-users world-wide and promoted by governments too. Role of DRE for the creation of Microgrid and Nanogrid systems were must, along with integration of Utility grid and communication using cyber-physical elements. As cyber-physical systems (CPS) are ancillary requirements in past decade but now it is a technology without which system reliability, security and stability all were in stack. In this research, resilience of microgrid and cyber-physical arena is taken in to consideration.

I INTRODUCTION

With the advent of technology generation of power and distribution is restructured almost in every decade or two due to major breakthrough. As the world is now having faster communication and the storage of data is now that much tedious task, now most of the devices are having inter device connectivity. So as the case with this advancement lead to change in communication and controlling of Power Systems. Now a days power system are mostly differentiated to smaller units called Nanogrid or Microgrids whose integral part or super set lead to formation of Power Systems operations. Microgrids are now days having the smarter capability of controlling, forecasting, data logging and decision making between the load end and utility for bidirectional flow of power. Microgrids are mostly termed as self-sustained in power generation which is of integration of Distributed Renewable Energy Sources, Utility grid and Diesel generations' too.

There is smart controlling required utilizing the power of the most convenient and cost effective source among the integration scheme. With the introduction of modern power electronics controller having embossed characteristics' of cyber-physical connection between different directly connected or indirectly connected devices via internet, empowered users to control the load according to economics values. With the introduction of Cyber-Physical Systems (CPS) security issues and power systems operations were to be modified with their integration to work within the limits of stability and security. Power system is having inherent capability to bring itself in stability while working in security limits are known as Resilience of the system, despite of sudden disturbances and turbulences to work under the limits. With the integration of modern smart controlling techniques along with cyber-physical system, threat of the system security is always concern, so the resilience behavior of the system is also to be taken in considerations.

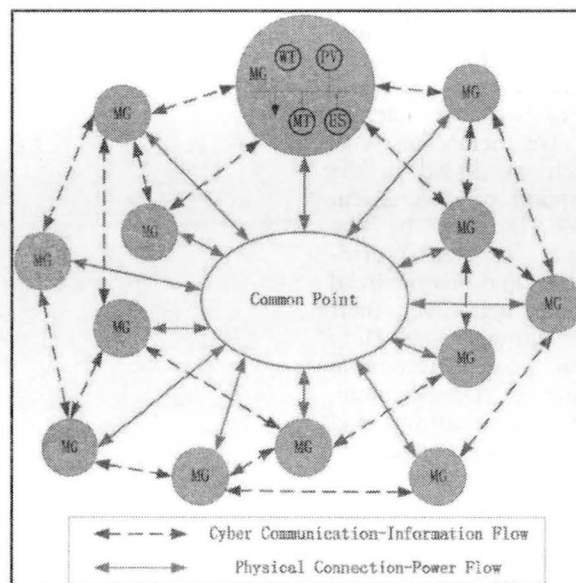

Fig. 1 Micro grid and Cyber-physical System Interaction.

Modern systems are influenced by the IOT (Internet of Things) along with incorporation of Cloud data communication and its utilization for data logging. This technology enables system to have peer to peer communications and level of IOT communication was also increased. Classifications of different CPS in Figure 2 are presented and interaction of CPS with elements of Microgrids and super-set of power systems are presented in Figure 1. Different states of Cybermatics will penetrate different stages of the

systems and security limits. Evolution of CPS is from computer networking followed by Internet of Computers (IoC) then IOTs' which is further strengthen by concept of Hyper IOTs' this is the process by which interconnection of Computer and its processing were shared. With the advent of this technology Hyper IOTs' were involved in microgrid integral features for communication of different parameters and their controlling by data-logging and continuous monitoring.

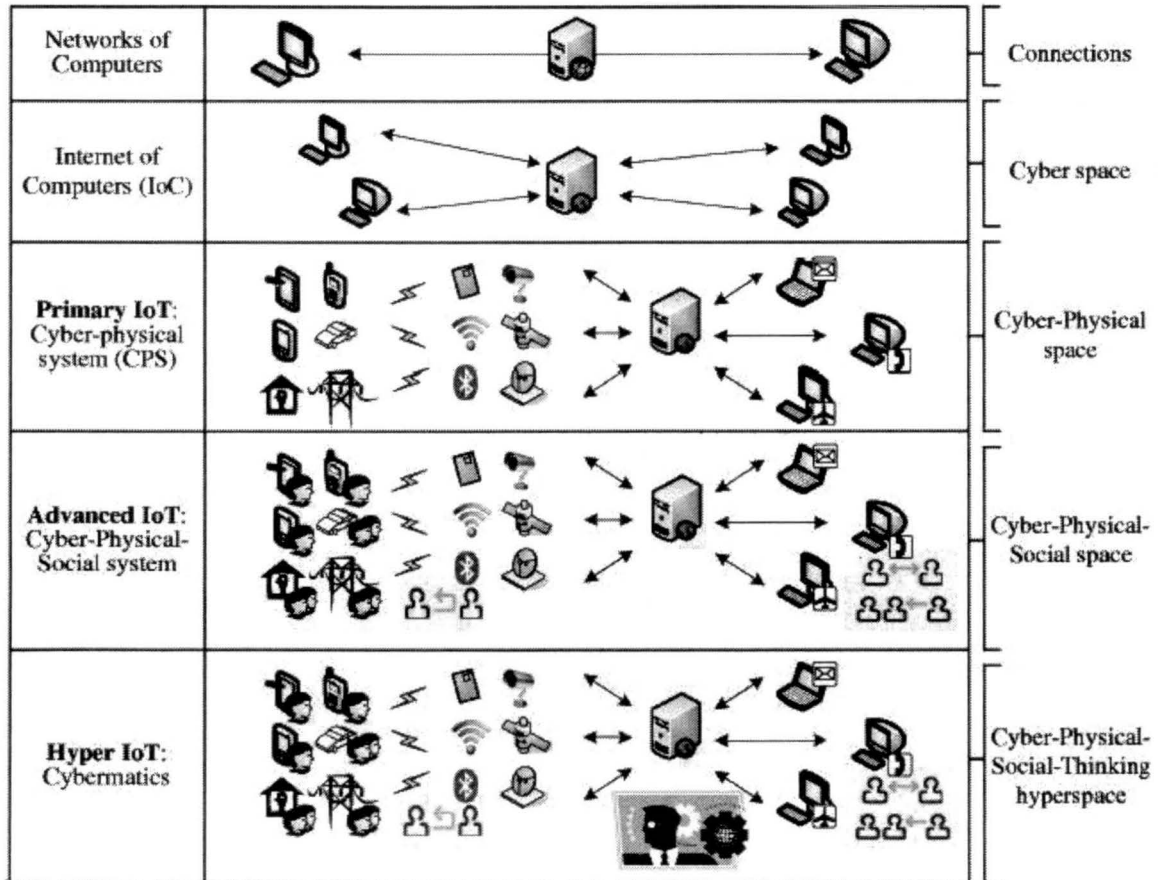

Fig. 2: Cyber-Physical System Classifications

II NEW PARADIGM IN MICRO GRID

As the power systems from its evolutions is being restructured in every Decade or half. Due to introduction of new break through technological revolutions which are dominating and efficiently utilizable for future perspective.

Traditional way of power generation is having unidirectional flow of power which creates the fixed topology of the systems as represented in Figure 3.

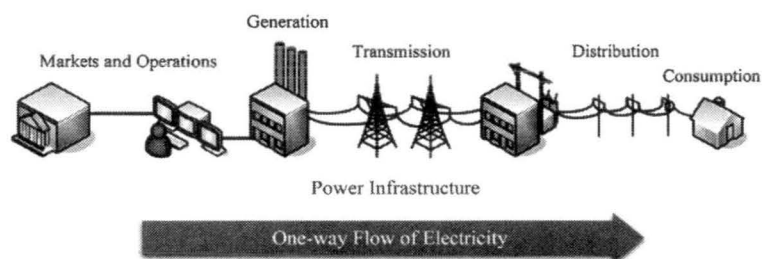

Fig. 3 Traditional Power Grid

In the traditional power systems interconnection between the different stages were only for the purpose of seeking operation parameter and security analysis. Where in the modern power systems data logging of the parameters were done by storing this data in cloud servers and continuous comparative analysis. With the modernization of system decentralized generation is promoted instead of

centralized generation approach which promotes Distributed Generation using renewable Technology. In the Distributed Renewable Energy Sources solar, wind, fuel cells, etc were used for generation of electricity along with their integration to utility and localized backup generation units, this system popularly known as Microgrid in present era.

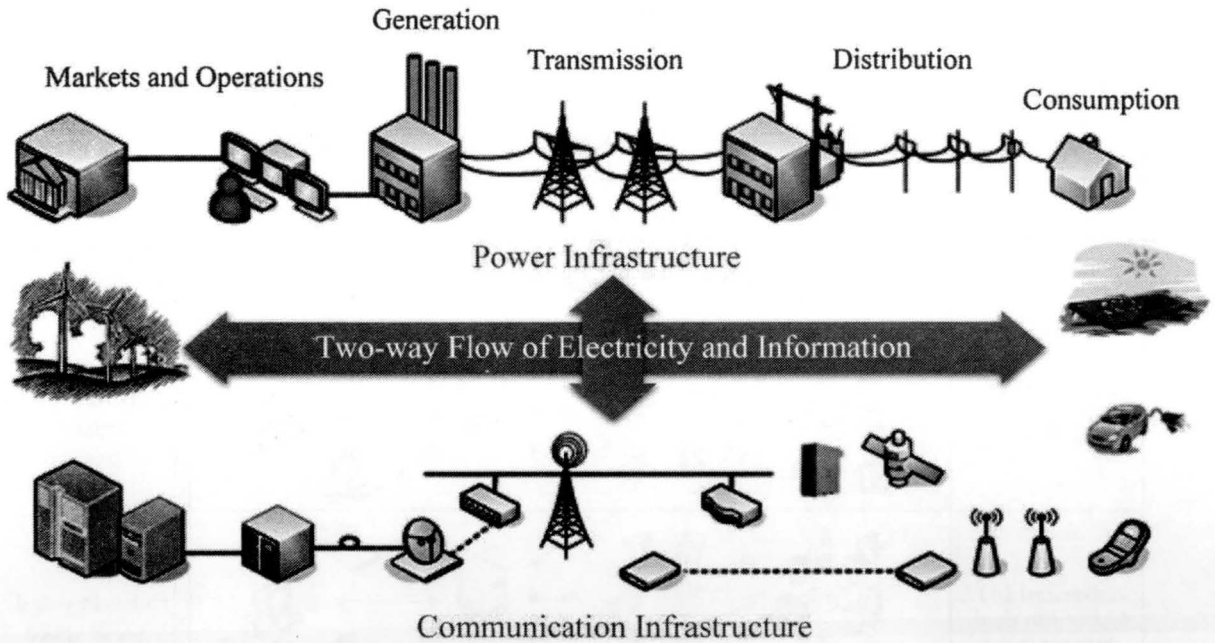

Fig. 4 Future Smart Grid

Microgrid is now getting advance day by day with embossment of Internet connectivity between generation system and load appliances to maintain the demand side managements, which change the economic scenarios. Microgrids enable the bidirectional flow of power in the system which is beneficial for the users and utility to utilize the diversity in power systems. This type of systems required well-tuned converters with proper connectivity and synchronization. However, due to the trends listed above, newer systems with greater

capabilities are already being put to use; power flow can be bidirectional and variations can occur in minutes or even seconds. Figure 1.5 illustrates the impact of these new trends on the power flow.

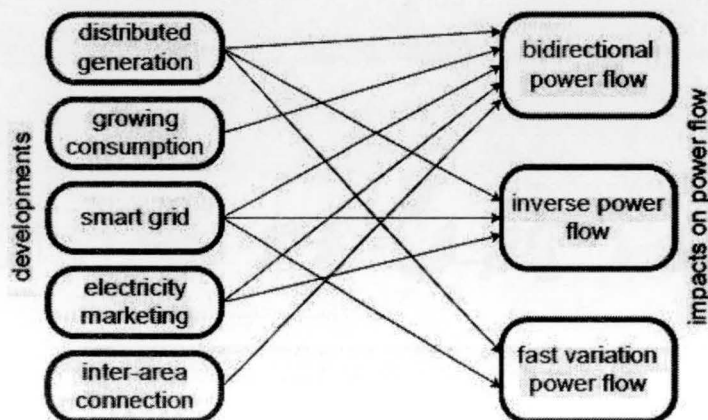

Fig. 5: Relation chart of the trends and their impact on the power flow

As the systems are getting smarter day by day with the increase in microgrids node in power systems as shown in Figure 1.1, CPS are introduced which are crucial in now a days in terms of security limits and operation of system without vulnerability. As interdependent power system and CPS will create Hyper IOT systems which is itself a complex and rigid affair in case of security and operational impingements'. As power pool and its controlling is totally dependent on the continuous feedback of operation in power plants and followed by distribution and transmission systems; any miscommunication and error will cramp the whole

systems for temporary or permanent failures which is undesirable. Thus with inculcation of CPS will increase the security issues although the ease of operation and controlling are facilitating concepts, but with advancement it is desired aspect.

III VOLTAGE REGULATION

Voltage regulation of a transmission line is defined as the rise in voltage at the receiving-end, expressed as percentage of full load at a specified power factor is thrown off, i.e.,

$$\text{Per cent regulation} = \frac{V_{RO} - V_{RL}}{V_{RL}} \times 100$$

Where,

V_{RO} Magnitude of no load receiving – end voltage

V_{RL} Magnitude of full load receiving – end voltage at a specified power factor [Kundur, 1993]

IV MICRO GRID CONTROLS

Control of every system is desired, with the advancement new controlling and operational techniques are also evolving which are

communicably supportive to other devices. Microgrid is also having few control arenas on the basis of which new topology for control and operations were developed. The control techniques were shown in figure 1.6.

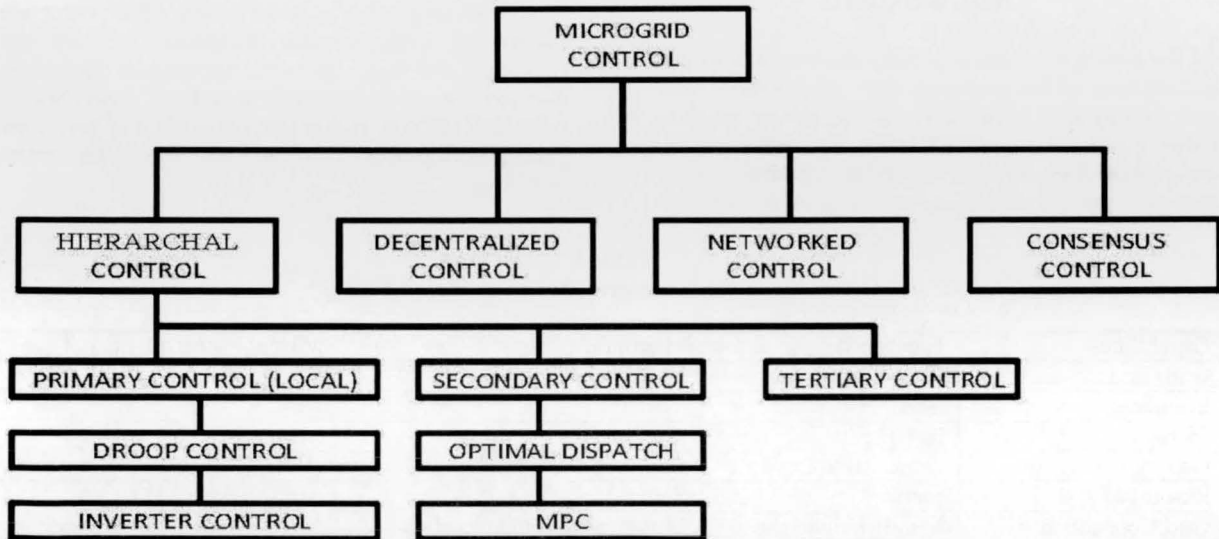

Fig. 6 Microgrid Control

In our research Hierarchical Control system is used in coordination with networked control, as the era of correlations were now sustaining. The CPS will enable the resilience characteristic of smart-grid by empowering the power pool with the flow of information and parameters comparison to the reference sets. As the power grids are now a day are having Distributed Renewable Energy (DRE) sources forming subsets as Microgrid and Nanogrid interconnected and isolated from utility grid on the

basis of topologies. Microgrids are equipped with features of bidirectional flow of power and self-generation of power on the demand of load. This type of feasibility of Demand Side Managements' in microgrids popularized the use of Cyber-Physical-Systems.

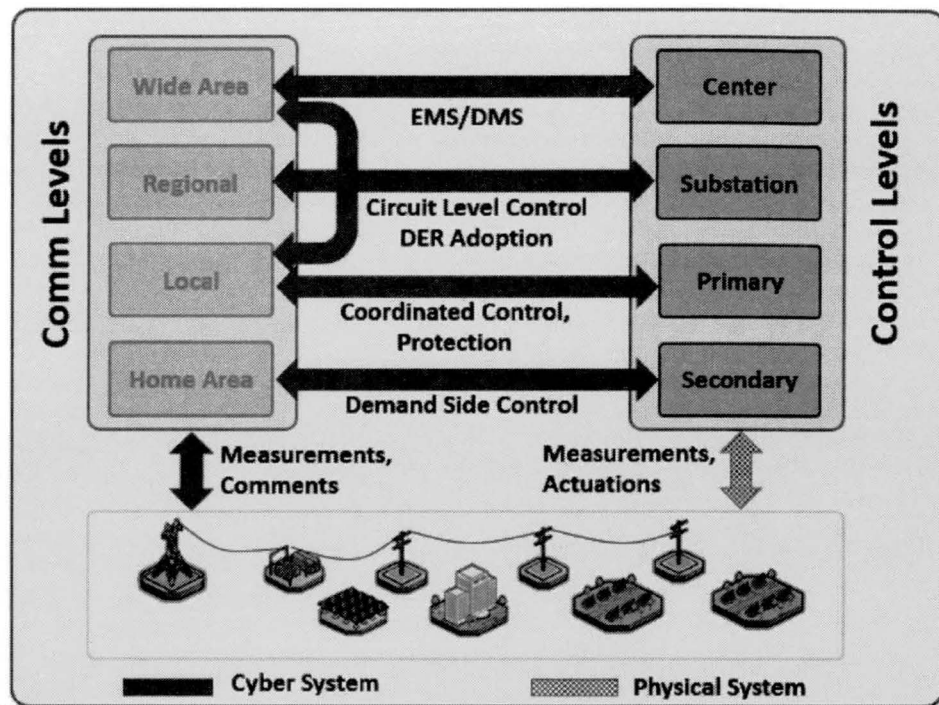

Fig. 7 Correlations between CPS

V CYBER AND PHYSICAL LAYER CORRELATION WITH MICROGRID

As the power a system is getting automated with the introduction of Bidirectional flow of power at end user is also now considered. In the power systems Cyber Fusion Points (CFP) nodes are created which are responsible for the up-streaming and down-stream communication and will help in economical

decision making for microgrid operations. In smart microgrid bidirectional flow of power and communication are key inherent characteristics. As smart metering helps in understanding the power use pattern of each specific customer and by the microgrid and smart metering data power flow to be decided for each customer based on consumption pattern. This will encourage dynamic and real time pricing of power used in addition with smart metering.

Table 1
Comparison for Nano-grid, Micro-grid and VPP

Capabilities	Nanogrid	Microgrid	Virtual Power Plants
Grid-Tied	Yes	Yes	Yes
Islanding	Yes	Yes	No
Storage	Required	Required	Sometimes
Geographic Range	Confined to Load	Confined to Networks	Wide & Variable
Resource Mix	Static	Static	Mix-Match
Grid Connection	Mostly behind the meters	Mostly behind the meters	Mostly transmission Mode
Market Impact	Retail	Retail first then wholesale	Wholesale first then Retail

Cyber-controlled Micro grid consists of many distributed generators' which incorporates smart load appliances and effective communication among device and source. Smart microgrid based on CPS will have three essential integrated elements: Sensing and Measurement technology; Smart Transducers'; Communication tools, this will form the base to operate the system within resilience and security limits. As microgrid is part of wide-area systems its operation and congestion will impact the dynamics of the systems. In Figure 1.7 different communication and control levels are defined, this describes the

penetration of cyber-physical systems in operation of smart microgrid.

Cyber-Physical Systems are mainly frame in which different devices of power generation, controlling, transmitting were interconnected together in Hyper-IOTstate of logical Cybermatics. In the operation of power systems its generation, transmission and distribution along with protection of system is in same hierarchy only by correct implementation of CPS at CFP nodes will transform the operation. Microgrids are essential in islanded condition in remote areas where arrangements for the transmission connectivity is challenging, in such area

microgrid with renewable energy source are utilized. This specific and essential utility support this system along with stand-alone self-roof-top and distributed generation system with smart home appliances.

VI CONCLUSION

With the advancement of technology transformation are essential, same is with the power systems. Microgrid with smart metering and CPS are now effectively used. As the power systems operation stability and security limits should not be violated. In this review paper the present scenario of power systems paradigm shift and operation with IOT, IOC and CFP nodes are established. This research is useful for the Microgrid and Nanogrid operation and control systems planning.

REFERENCES

- [1] Singh Sandeep Kumar , Khanna Kush, Bose Ranjan, Panigrahi Bijaya Ketan, Joshi Anupam, “Joint Transformation based Detection of False Data Injection Attacks in Smart Grid”, *IEEE Transactions on Industrial Informatics, Volume: 14, Issue: 1, Jan. 2018, Page(s): 89 – 97, Year: 2018*
- [2] Utkarsh Kumar, Srinivasan Dipti, Reindl Thomas, Trivedi Anupam, “Grid Ancillary Service using Distributed Computational Intelligence based control of Renewables and Storage Systems in a Distribution Network”, *IEEE Congress on Evolutionary Computation (CEC), pages: 1412 – 1419, Year: 2017*
- [3] Kanellos Fotis D., “Real-Time Control based on Multi-Agent Systems for the Operation of Large Ports as Prosumer Microgrids”, *IEEE Access, pages: 9439 – 9452, Year: 2017*
- [4] Taplamacioglu M. Cengiz, Gözde Haluk, Ari Murat, “Simulation Study For Global Neighborhood Algorithm Based Optimal Automatic Voltage Regulator (AVR) System”, *IEEE, 5th International Istanbul Smart Grids and Cities Congress and Fair, ICSG Istanbul, pages: 46 – 50, Year: 2017*
- [5] Zhao Long, Yang Zhiyong , Lee Wei-Jen, “The Impact of Time of Use (TOU) Rate Structure on Consumption Patterns of The Residential Customers”, *IEEE Transactions on Industry Applications, Volume: 53, Issue: 6, Pages: 5130 - 5138, Year: 2017*
- [6] Liu Zhaoxi; Wu Qiuwei; Huang Shaojun; Zhao Haoran , “Transactive energy: A review of state of the art and implementation”, *IEEE Manchester PowerTech, , Pages: 1 - 6 Year: 2017*
- [7] Wu Libing; Zhang Yubo; Choo Kim-Kwang Raymond; He Debiao; “Efficient Identity-based Encryption Scheme with Equality Test for Smart City”, *IEEE Transactions on Sustainable Computing, Volume: PP, Issue: 99, Pages: 1 - 1, Year: 2017*
- [8] Rana Rubi, Singh Mukesh, Mishra S., “Design of Modified Droop Controller for Frequency Support in Microgrid using Fleet of Electric Vehicles”, *IEEE Transactions on Power Systems, Volume: 32, Issue: 5, Sept., Page(s): 3627 – 3636, Year: 2017*
- [9] Vaahedi Ebrahim, Nodehi Kash, Heim David, Rahimi Farrokh, Ipakchi Ali , “The Emerging Transactive Microgrid Controller”, *IEEE Power & Energy Magazine, Issue: July/August 2017*
- [10] Tavares Suzanne Emanuelle; Luiz Alexander A.; Stopa Marcelo M.; Pereira Heverton A. “Bidirectional power converter with adaptive controller applied in direct-current microgrid voltage regulation”, *2017 IEEE 8th International Symposium on Power Electronics for Distributed Generation Systems (PEDG), Pages: 1 - 6, Year: 2017*
- [11] Mudaliyar Shiv Raman, Mishra Sukumar, Sharma Rishi Kant, “Coordinated controller design and stability analysis of DC microgrid with constant power load”, *2017 IEEE Second International Conference on DC Microgrids (ICDCM), Pages: 322 – 329, Year: 2017*
- [12] Du Yan, Zhang Beilei, Yang Xiangzhen, Mao Meiqin, Li Hua, Chang Liuchen, “A decentralized multi-framed droop-controller for improving harmonic power sharing in an islanded microgrid”, *2017 IEEE 3rd International Future Energy Electronics Conference and ECCE Asia (IFEEEC 2017 - ECCE Asia), Pages: 1725 – 1730, Year: 2017*
- [13] Anurag S D Rai, C S Rajeshwari, Anjali Potnis, “Voltage fluctuation and regulation improvement through the genetic algorithm based DPFC in a power transmission system”, *Eduved International Journal of Interdisciplinary Research, ISSN 2348-6775 (online), Vol. 01 Issue 05 Aug 2014.*