

# Coupled-structure erbium-doped fiber amplifier with 94-nm bandwidth

## Kuo-Hsiang Lai

National Chiao Tung University  
Department of Photonics and Institute of  
Electro-Optical Engineering  
1001 Ta-Hsueh Road  
Hsinchu 300, Taiwan  
and  
Chunghwa Telecom Company, Ltd.  
Yang-Mei, Taoyuan 326  
Taiwan  
E-mail: lkh@cht.com.tw

## Chien-Hung Yeh

Industrial Technology Research Institute  
Computer and Communications  
Research Laboratories  
Chutung, Hsinchu 310  
Taiwan

## Sien Chi

National Chiao Tung University  
Department of Photonics and Institute of  
Electro-Optical Engineering  
1001 Ta-Hsueh Road  
Hsinchu 300, Taiwan  
and  
Yuan Ze University  
Department of Electrical Engineering  
Chung-Li 320, Taiwan

## 1 Introduction

Wide-band erbium-doped fiber amplifiers (EDFAs) have caused considerable interest in high capacity in dense wavelength division multiplexing (DWDM) systems. However, the transmission capacities in DWDM systems are limited by the gain bandwidth of conventional band erbium-doped fibers (EDFs) between 1530 to 1560 nm. Furthermore, *L*-band (1560 to 1610 nm) fiber amplifier techniques have been achieved, such as EDFAs, by using a longer EDF than that of *C*-band EDFAs,<sup>1</sup> fiber Raman amplifiers,<sup>2</sup> and different hybrid amplifiers.<sup>3</sup> In addition, a wide-band EDFA from *C* to *L* band, employing the coupled structure, has also been studied.<sup>4</sup> Recently, a new *S*-band (1450 to 1530 nm) amplification technique, which utilizes erbium-doped silica fiber with depressed cladding design and a 980-nm pump laser to generate EDF gain extension effects, has been reported.<sup>5</sup> By using a coupled-structure with the new *S*-band EDFA and erbium-doped waveguide amplifier (EDWA) module,<sup>6</sup> it can retrieve the wide-gain bandwidth from the *S* to *C* band. We have proposed and experimentally demonstrated a coupled-structure *S*- to *C*-band EDFA module with 96-nm gain bandwidth of 1476 to 1570 nm. In addition, the performance and behavior of this proposed EDFA module has also been studied.

**Abstract.** A novel *S*- to *C*-band erbium-doped fiber amplifier (EDFA) module over a 94-nm operation wavelength from 1476 to 1570 nm is experimentally investigated and demonstrated. This proposed module composes an *S*-band EDFA and a *C*-band erbium-doped waveguide amplifier (EDWA) with a coupled-structure. The 31.4-dB peak gain with 5.6-dB noise figure, and 30.5-dB peak gain with 4.7-dB noise figure are observed at 1506 and 1534 nm in this configuration when the input signal power is  $-30$  dBm, respectively. © 2005 Society of Photo-Optical Instrumentation Engineers. [DOI: 10.1117/1.1899423]

Subject terms: erbium-doped fiber amplifier; wide band; coupled structure; wavelength division multiplexing systems; *S* band.

Paper 040515R received Jul. 31, 2004; revised manuscript received Nov. 7, 2004; accepted for publication Nov. 16, 2004; published online Apr. 22, 2005.

## 2 Experiments and Discussions

The experimental setup for the wide-band EDFA module from *S* to *C* band by using a coupled structure is shown in Fig. 1. This configuration is constructed by two 1480/1550-nm WDM couplers ( $W_2$ ), an *S*-band EDFA module composed of two EDFA stages and a power-sharing 980-nm pump laser, and a *C*-band EDWA module. Two WDM couplers ( $W_2$ ) were used to connect two amplifier modules in parallel, and the output ranges of ports 1, 2, and 3 were 1480 to 1600 nm, 1480 to 1520 nm, and 1520 to 1600 nm, respectively, as seen in Fig. 1. The *S*-band erbium-doped fiber inside the EDFA module has a depressed cladding design to provide a sharp, high-attenuation, long-wavelength cutoff filter to active fibers. Moreover, the composition of the core is approximately 2.5% GeO<sub>2</sub>, 5.5% Al<sub>2</sub>O<sub>3</sub>, and 92% SiO<sub>2</sub>, with 0.15 wt % erbium. The depressed cladding is approximately 3% fluorine, 0.5% P<sub>2</sub>O<sub>5</sub>, and 96.5% SiO<sub>2</sub>. The core and cladding diameters are 4 and 22  $\mu$ m, respectively. The numerical aperture of the core, relative to the depressed cladding, is 0.22 and the cutoff wavelength is near to 1530 nm. The background loss is less than 5 dB/km. This *S*-band EDFA was fusion spliced to a SMF-28 fiber using a standard setting. Typical splice losses were 0.5 dB. The erbium-doped fibers in the first and second stages have different characteristics. The fiber in the first stage, which has the fiber length of 20 m, provides low noise figure and medium gain by forward pumping. The length of the fiber in the second stage is 30 m, and this fiber could produce large output

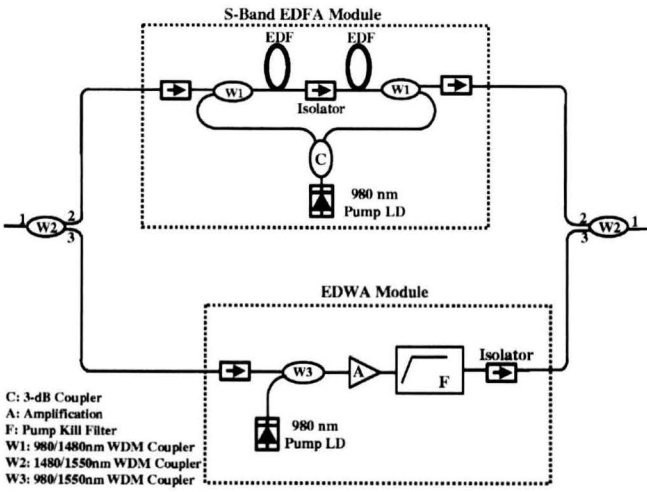

**Fig. 1** Experimental setup for the wide-band EDFA module from S to C band.

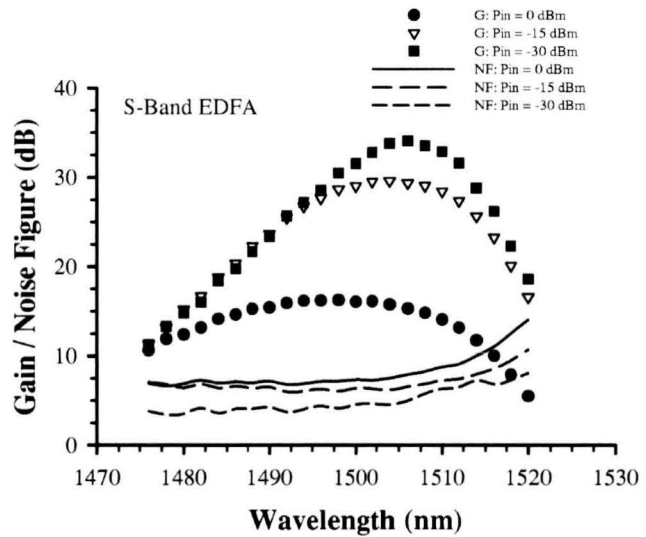

**Fig. 2** Gain and noise figure spectra for the S-band EDFA module with the input signal powers  $P_{in}=0, -15,$  and  $-30$  dBm, respectively.

power by backward pumping. In addition, the optical isolator between these two stages would reduce backward amplified spontaneous emission (ASE) and improve noise figure performance. The total pump power of this amplifier module could be up to 280 mW, while the bias current is operated at 356 mA. Furthermore, the evolution from a standard EDFA to this S band is designed by the introduction of a continuous long-wavelength cutoff filter in the erbium-doped fiber. Although the spectrum indicates a strong gain at S-band wavelengths, the gain cannot be realized because of strong ASE at the 1530-nm peak, which limits the length of the population inversion. Introduction of a progressively sharper long-wavelength cutoff filter suppresses the gain in the C and L bands, so that the S band region could exhibit increasing gain, as ASE from the 1530-nm peak does not grow and limits the population inversion. The final result is a complete suppression of the longer wavelength gain, resulting in a usable high net gain in the S band.

To ensure the performances for this proposed amplifier module shown in Fig. 1, the input signal powers  $P_{in} = -0, -15,$  and  $-30$  dBm are used to probe the gain and noise figure spectra, respectively. Figure 2 shows the gain and noise figure of the S-band EDFA is 34.3 and 5.0 dB at 1506 nm when the input signal power is  $-30$  dBm, and the saturated output power at 1498 nm would be up to 16.3 dBm for an input power of 0 dBm with 7.1-dB noise figure, as shown in Fig. 2.

The EDWA has the advantages of the EDFA, such as low noise figure, low polarization dependence, and no cross talk between WDM channels. Besides, this EDWA module could generate high gain in a very short optical path, and 15-dB gain would be obtained in the gain medium of only 5 cm. Furthermore, this EDWA module has the feature of a 4.5-dB noise figure over the entire C band, 15-dB small signal gain, and 12-dBm output power when the double-pump scheme is used, and the pump current of 440 mA is applied at ambient temperature. In addition, optical isolators would be used to reduce backward amplified spontaneous emission (ASE) and improve noise figure performance.

In the view of compactness and functionalities, fiber wavelength division multiplexers (FWMs), a pump kill filter, an uncooled laser pump, and optical isolators are all attached directly into the EDWA module. Therefore, the size of this packaged block is just about  $40 \text{ cm}^3$  and is 1/5 the typical size of EDFA. Figure 3 shows the gain and noise figure spectra of the original EDWA shown in Fig. 1 over the bandwidth of 1526 to 1570 nm with input signal powers  $P_{in}=0, -15,$  and  $-30$  dBm, respectively. The gain and noise figure would achieve 33.2 and 4.2 dB at 1534 nm, while the input signal power is  $-30$  dBm. The saturated output power at 1542 nm could be up to 11.2 dBm for input power of 0 dBm, as seen in Fig. 3. Moreover, a gain larger than 10 dB is observed in Fig. 3 when the input signal power is  $>-15$  dBm over the wavelengths of 1526 to 1570 nm.

Figure 4 presents the insertion loss spectra of ports 2 and 3 for two 1480/1550-nm WDM couplers, and two loss curves fold downward at around 1522 nm. Figure 5 indi-

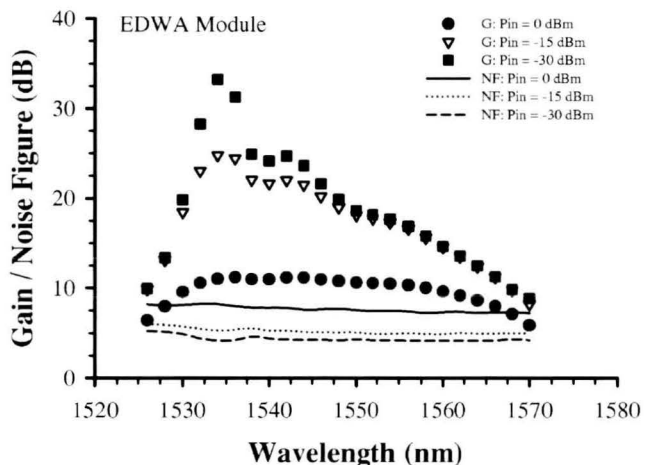

**Fig. 3** Gain and noise figure spectra for the EDWA module with the input signal powers  $P_{in}=0, -15,$  and  $-30$  dBm, respectively.

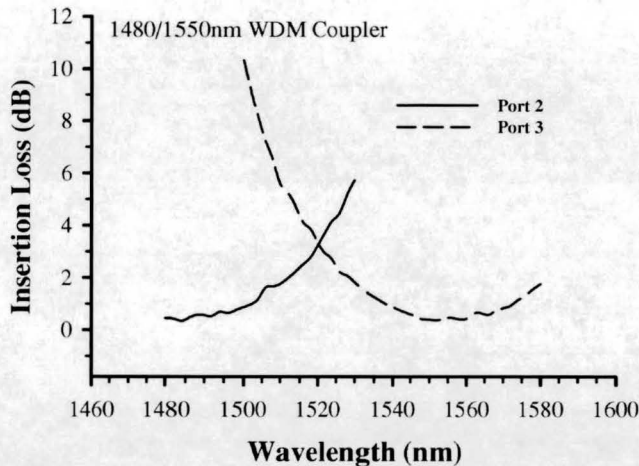

Fig. 4 The insertion loss of 1480/1550-nm WDM coupler versus operating wavelengths.

compares the gain and noise figure spectra of the proposed wide-band amplifier module shown in Fig. 1 between the wavelengths of 1476 to 1570 nm with the input signal powers  $P_{in}=0$ ,  $-15$ , and  $-30$  dBm, respectively. Due to the insertion loss of two WDM couplers, the different gain spectra of this proposed amplifier is smaller than that of the S- and C-band amplifier individually, and the gain spectra drops at near 1522 nm, as seen in Fig. 5. However, the wide gain bandwidth was over 94 nm, as we expected. The 31.4-dB peak gain with 5.6-dB noise figure, and 30.5-dB peak gain with 4.7-dB noise figure would be observed at 1506 and 1532 nm, respectively, when the input signal power  $P_{in}$  is  $-30$  dBm. Compared with the mentioned S- and C-band amplifier module individually, the noise figure only degrades about 0.4 to 1 dB from 1476 to 1570 nm, as shown in Fig. 5. Based on the gains and noise figures of the EDWA and S-band EDFA, and the insertion loss of the WDM, the difference between the experimental results and the calculated results for the overall output gain and noise

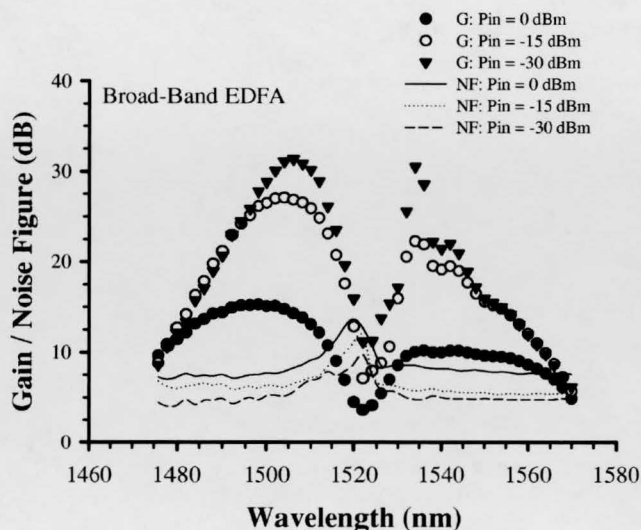

Fig. 5 Gain and noise figure spectra of the proposed configuration with the input signal powers  $P_{in}=0$ ,  $-15$ , and  $-30$  dBm, respectively.

figure from the proposed module are less than  $\pm 0.8$  and  $\pm 0.5$  dB, respectively. The insertion loss of the bandpass coupler seems a little high in the 1520-nm range, and the consequent amplifier noise figure in that region is well over 10 dB for all input conditions for the wavelengths from 1514 to 1524 nm, as shown in Fig. 5. This phenomenon could be possibly improved when the insertion losses of two bandpass couplers are reduced. According to Fig. 5, the gain and noise figure spectra also show good performance when three different input signal power levels are applied in the experiment, respectively. Therefore, the proposed EDFA could be used to act as the in-line, pre-, or post-amplifier in optical WDM systems. Compared with past broadband amplifier techniques,<sup>7,8</sup> which used a thulium-doped fiber type or Raman amplification, the proposed module that employs two EDF-based amplifiers in parallel configuration over the gain bandwidth from 1476 to 1570 nm has the advantage of wide bandwidth, potentially lower cost, and simple architecture.

### 3 Conclusion

We experimentally investigate and demonstrate a new S-plus C-band EDFA module in parallel structure over 94-nm gain bandwidth of 1476 to 1570 nm with a gain of  $>10$  dB (for the input signal power  $>0$  dBm) over the operation range. For the proposed EDFA, 31.4-dB peak gain with 5.6-dB noise figure, and 30.5-dB peak gain with 4.7-dB noise figure could be observed at 1506 and 1532 nm, respectively, while the input signal power is  $-30$  dBm. Because of the wide bandwidth, large gain, and low noise figure, this novel coupled-structure EDFA could be applied in DWDM optical networks.

### Acknowledgment

This work was supported in part by the National Science Council (NSC) of Taiwan under grants NSC 93-2752-E009-009-PAE, NSC 93-2215-E-115-004, and NSC 93-2215-E-115-005.

### References

1. Y. Sun, J. W. Sulhoff, A. K. Srivasta, J. L. Zyskind, T. A. Strasser, J. R. Pedrazzani, C. Wolf, J. Zhou, J. B. Judkins, R. P. Espindola, and A. M. Vengsarkar, "80 nm ultra-wideband erbium-doped silica fiber amplifier," *Electron. Lett.* **33**(23), 1965-1967 (1997).
2. S. Namiki and Y. Emori, "Ultra-band Raman amplifiers pumped and gain-equalized by wavelength-division-multiplexed high-power laser diodes," *IEEE J. Sel. Top. Quantum Electron.* **7**, 3-16 (2001).
3. H. Masuda and S. Kawai, "Wide-band and gain-flattened hybrid fiber amplifier consisting of an EDFA and a multiwavelength pumped and Raman amplifier," *IEEE Photonics Technol. Lett.* **11**, 647-649 (1999).
4. B. Min, H. Yoon, W. J. Lee, and N. Park, "Coupled structure for wide-band EDFA with gain and noise figure improvement from C to L-band ASE injection," *IEEE Photonics Technol. Lett.* **12**, 480-482 (2000).
5. M. A. Arbore, Y. Zhou, G. Keaton, and T. J. Kane, "30 dB gain at 1500 nm in S-band erbium-doped silica fiber with distributed ASE suppression," *Proc. SPIE* **4989**, 47-52 (2003).
6. K. C. Reichmann, P. P. Iannone, M. Birk, N. J. Frigo, D. Barbier, C. Cassagnettes, T. Garret, A. Verlucco, S. Perrier, and J. Philipsen, "An eight-wavelength 160-km transparent metro WDM ring network featuring cascaded erbium-doped waveguide amplifiers," *IEEE Photonics Technol. Lett.* **13**, 1130-1132 (2001).
7. K. Fukuchi, T. Kasamatsu, M. Morie, R. Ohhira, T. Ito, K. Sekiya, D. Ogasahara, and T. Ono, "10.92-Tb/s (273×40-Gb/s) triple-band/ultra-dense WDM optical-repeated transmission experiment," in *OFC'2001*, paper PD24 (2001).

8. N. E. Jolley, "Demonstration of low PMD and negligible multi-path interference in an ultra flat broad EDFA using a highly doped erbium fibre," in *Conf. Opt. Amplifiers Applications '98*, pp. 124-127 (1998).



**Kuo-Hsiang Lai** received the BSEE degree from the electrical engineering department of National Cheng Kung University, and MSc degree from the Institute of Optical Science of National Central University, Taiwan, in 1987 and 1989, respectively. He is currently studying at the Department of Photonics and Institute of Electro-Optical Engineering of National Chiao Tung University, Taiwan. He is also working at Broadband Transport and Access Technology Laboratories of the Telecommunication Laboratories, Chung-hwa Telecom Company, Limited, Taiwan. His current research interests are optical fiber communications, fiber lasers and EDFA technologies for optical networks, and technologies and applications of DWDM in broadband access networks.



**Chien-Hung Yeh** received the BS and MSc degrees from the physics department of Fu Jen Catholic University, Taiwan, in 1998 and 2000, respectively. He received his PhD degree from the Institute Electro-Optical Engineering, National Chiao Tung University, Taiwan, in 2004. His current research interests include fiber laser technologies for optical networks, and optical switching and applications of EDFA for WDM transmission. He is now working at the Computer and Communications Research Laboratories, Industrial Technology Research Institute, Taiwan.



**Sien Chi** received his BSEE degree from the National Taiwan University and his MSEE degree from the National Chiao Tung University, Taiwan, in 1959 and 1961, respectively. He received his PhD in electrophysics from the Polytechnic Institute of Brooklyn, New York, in 1971, and he then joined the faculty of National Chiao Tung University, where he was vice-president of the university from 1999 to 2001. He is currently a professor in the Department of Photonics and Institute of Electro-Optical Engineering. From 1972 to 1973 he chaired the Department of Electrophysics; from 1973 to 1990 he directed the Institute of Electronics. From 1993 to 1996 he received the Distinguished Research Award sponsored by the National Science Council, Taiwan. Since 1996 he has been the chair professor of the Foundation for the Advancement of Outstanding Scholarship. His research interests are optical fiber communications, optical solitons, and optical fiber amplifiers. He is a fellow of the Optical Society of America and the Photonics Society of Chinese-Americans.