

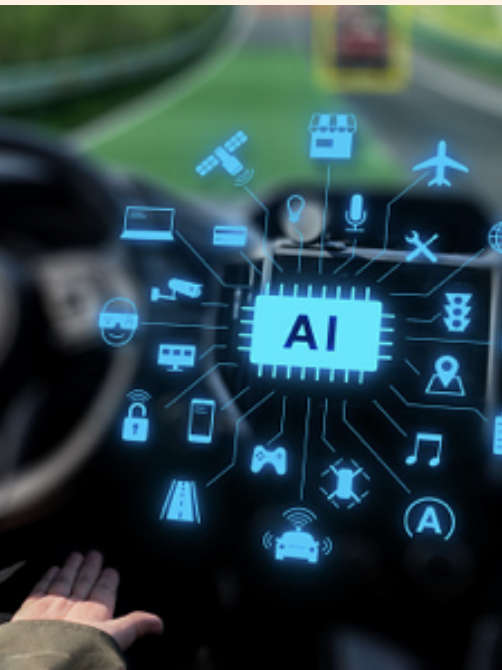

PRAXZINE

The praxeis newsletter



What's Charging?

READING GALLERY:

"It (Automated Driving System) may be safer and have more longevity, but who wants to do it?"
- Unknown

Inside:

Electric Vehicles: The Automobile Sector's Call Down • P2

Electric Vehicle Revolution in India • P3

Automated Driving System
The works, Technology and the Levels of Driving • P5

Supercars from Future • P6

Featured Article -

Fuelling sources and a futuristic approach to depollute • P9

Electric Vehicles: The Automobile Sector's Call Down

By Sayan Chatterjee



Electrical vehicles are by no suggests that replacement conception – they have been existing in some type of alternative since the nineteenth century.

By 1920, prohibitor costs, combined with restricted vary and low-cost oil contributed to a sharp decline in electric sales.

General Motors at the side of Toyota and different automakers ceased production of electrical vehicles citing restricted demand and sluggish battery technology development. Meanwhile, in the geographical area, Tesla was born.

Elon Musk deserves credit for revitalised the interest in electric vehicles.

The Road till Now

Electric vehicles are a growing marketplace for new automobile purchases with additional and more individuals creating the switch from the gasoline station to a receptacle to fuel their vehicles.

Electrical vehicles use electricity as their primary fuel or use electricity at the side of a traditional engine to enhance potency (plug-in hybrid vehicles).

Drivers see around \$700 in savings a year in gasoline expenses when they drive a mean of 12,000 miles. They can also understand substantial tax credits that encourage low-emission and emissions-free driving.

Extra advantages embrace environmental enhancements due to reduced vehicle emissions, energy independence by means of mistreatment locally-generated electricity and top-quality driving performance.

This fashion towards electric-powered cars is predicted to continue, especially with the billions being invested by car-makers.

Electric Vehicle Market to Hit Ludicrous Mode

Projected number of electric vehicles driving globally up to 2030*

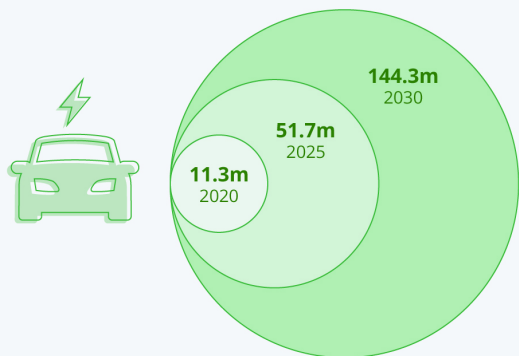

* Includes battery electric, fuel cell and plug-in hybrid cars, vans, buses and trucks. Source: International Energy Agency

IMPACT OF EV'S ON THE AUTOMOBILE INDUSTRY

Automakers

- Automobile producers are making large investments in electric powered automobile divisions as they recognise that electric powered automobiles are disrupting the industry.

- Significant inner modifications will take vicinity as groups combat for his or her proportion of budgets in R&D sports and current powertrain heavyweights will refuse to step apart gracefully to electric-powered divisions.

- Many new delivery chain partnerships want to be created. The consciousness will flow to new technology as the car turns into a real PC on wheels.

Dealers

- Dealers will unlearn and learn how to promote each electric powered motor and traditional motors.

- Dealers must equip their employees with a varied skill set to promote electric powered motors.

- The automobile enterprise version is predicted to convert with the emergence of the electric vehicle.

- Profitability from carrier operations is predicted to return down as electric powered motors would require much less maintenance.

Suppliers

Suppliers may be notably affected as car producers transfer to the electrical powertrain. Only some providers who take suitable projects will live to tell the tale and succeed, together with Bosch that has a separate department to cognisance on batteries.

End Customers

- Incentives and subsidies will flip the tide in favour of electric vehicles.

- The quickly growing charging stations network combined with supercharging facilities will create the adoption of electric vehicles easier for the customer.

- Superior driving expertise with packed innovative options will make it tough for patrons to resist the experience of owning an electric vehicle. Once they drive an electric vehicle, they're going to notice it difficult to look back.

The Journey Ahead

The electric automobile is that the way forward for the machine mobile, and it's changing into a reality previously expected?

Future 5-10 years is (going to beware) an exciting part for the auto industry. Automobile makers can invest billions during this rising technology to remain relevant.

Although the electrical car divisions of automobile manufacturers are presently not a profitable business, the electric car tide will force them to explore it.

The prestigious divisions among automobile corporations will lose power.

They'll refuse to transfer power and cash to the electrical divisions.

There are similar precedents: Burroughs and Kodak refused to adapt to the rising changes and lost their means completely.

The major shift goes to be towards an electrical/electronic one, and also the focus will shift from engine management, emission control, and fuel potency to batteries, drive motors, and different aspects of technology. However, there may be another challenge - the supply of rare-earth element metals as an input raw material.

Atomic number 27 (a by-product of Copper / Nickel mining) may be a key ingredient for Lithium-ion batteries and will hit a roadblock in terms of a provide / demand mate once automobile makers go electric.

The electrical vehicle trade may be in bother as volumes grow and can get to explore various battery technologies to take care of the momentum.

ELECTRIC VEHICLE REVOLUTION IN INDIA

by Ayush

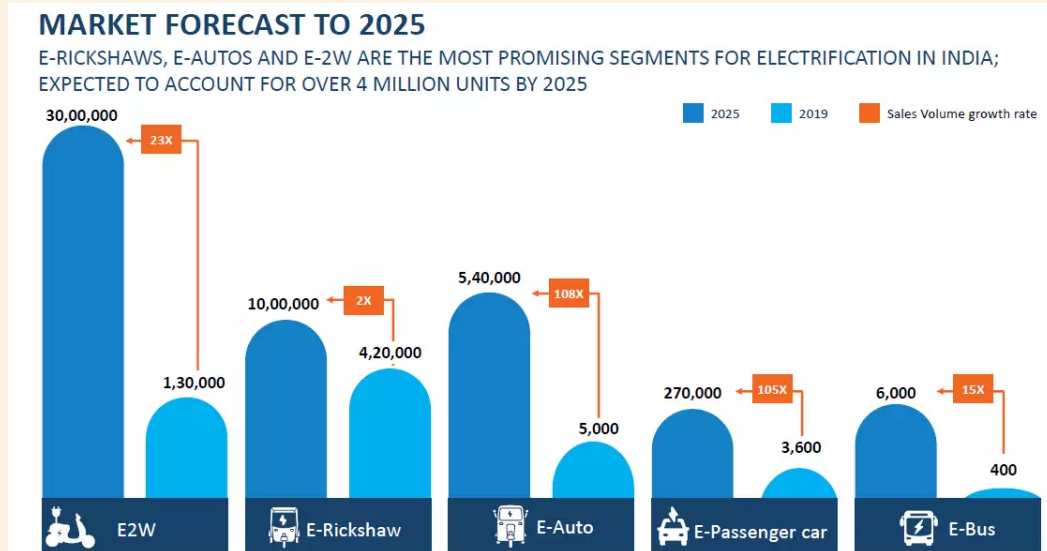

GROWTH TARGET OF EVs IN INDIA

India is one of the few countries to support the EV30@30 campaign, which aims to have at least 30% vehicle sales as electric by 2030. Being the fifth largest automotive industry and slated to be the 3rd in the world by 2030, India is looked upon as a huge potential for an electric revolution.

A survey states that the EV market of India would become a US\$206 billion opportunity by 2030. Another report predicts that the EV market of India will grow at a compound growth rate of 36% by 2026. However, given the ambitious targets, the shift from fuel-based vehicles to electric vehicles is not that easy after all.

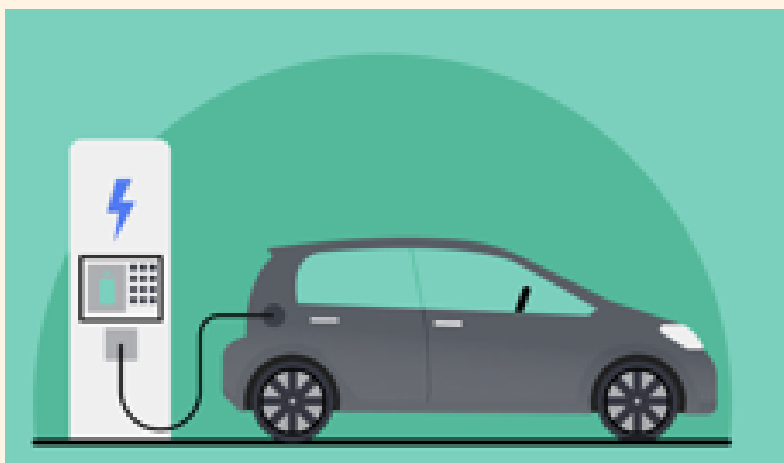





BARRIERS IN THE REVOLUTION

Change invites problems. Though there is a hefty number of benefits of EVs, making it widespread throughout the nation would be a tough task. The few common problems of owning an EV are-

1. Range anxiety- there would always be a question of whether the vehicle will reach the destination without running out of battery. This is closely related to the lack of charging stations in the country. Hence, this requires a stronger push for infrastructure.
2. Financing challenges- EV customers currently face various financing challenges such as limited financing options, high interest, high insurance cost, and limited loan opportunities. As EVs gain widespread adoption, these financing challenges can hinder EVs' widespread adoption in the country.
3. Limited choices- with the technology still being developed, there aren't a lot of options and models for customers to choose from. This can make customers buy other fuelled vehicles.

Who are making EVs in India today?

While established companies are slow to warm up to the transition to electric vehicles, lesser known entities and start-ups are stoking the change

 <p>Two wheelers ACE, Ajanta Manufacturing, Ampere, AVON Cycles, BPG, BSA, Chris Motors, Eko, Electrotherm (India), Hero Moto Corp, Honda India, Lohia Auto, Mahindra & Mahindra, Okinawa Autotech, Peugeot, Tunwal Electronics, TVS Motors, Ultra Motors, YO Bykes</p>	 <p>Three wheelers Bajaj Auto, Electrotherm (India), Mahindra & Mahindra</p>	
 <p>Four wheelers Mahindra & Mahindra</p>	 <p>Bus Volmac Engg., Volvo, Goldstone-BYD</p>	 <p>HDVs Volmac Engg., Volvo</p>

Source: CSE's market analysis

BENEFITS

According to a report by NITI Aayog, India can save 64% of anticipated passenger road-based mobility-related energy demand and 37% of carbon emissions in 2030 by pursuing a shared, electric, and connected mobility future. This would result in a reduction of 156 megatons of diesel and petrol consumption for that year. At USD 52/barrel of crude, this would imply a net savings of roughly Rs 3.9 lakh crore in 2030. These figures clearly indicate an urgent requirement for the replacement of conventional vehicles with electric vehicles. Among the world's 20 most polluted cities in the world, 13 are in India! Vehicular pollution is one of the major contributors to air pollution. India is in the group of countries that has the highest particulate matter (PM) levels requiring an exigency for Electrical Vehicles. As a signatory to the Paris climate agreement, India is obligated to bring down its share of global emissions by 2030. Thus, the government of India is making key initiatives such as the launch of the National E-Mobility Programme, planning guidelines to encourage the use of such vehicles by NITI Aayog etc. to promote EVs in India.

CONCLUSION

With the government pushing and investment in EVs by corporate giants, there's no doubt that the future of automotive industry in India will change extensively. Though the market in India has given a tepid response to electric vehicles but there exists immense opportunity for the growth of electric vehicles. The government of India is dedicated towards adoption of Electric Vehicles for a cleaner and greener environment. It will be interesting to see how people change their mindset towards EVs and implant the feeling of 'safety over performance'.

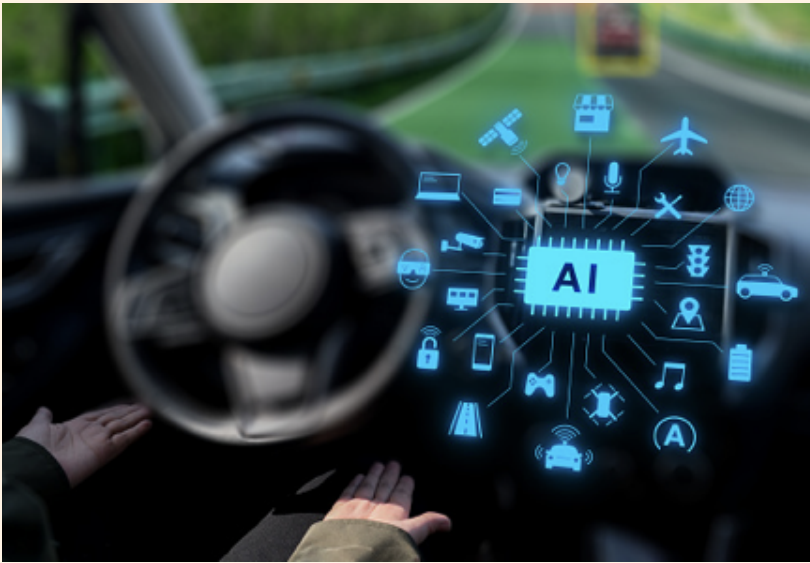

Automated Driving System The works, Technology and the Levels of Driving

by Heena Sharma

With robots replacing humans in different fields, which is the most recent area where individuals are being replaced by robots? Car drivers!

Autonomous driving or automated driving is commonly used to describe self-driving cars or transportation systems that operate without the involvement of a human driver.

Automotive companies are facing a self-driving-car disruption fuelled primarily by the tech industry, with many consumers anticipating their next automobiles to be completely autonomous as a result of the hype.

But, a closer look at the technology needed to reach advanced degrees of autonomous driving reveals a much longer time frame; such cars are likely 5 to 10 years away.

“It (Automated Driving System) may be safer and have more longevity, but who wants to do it?”

- Unknown

Technology

The autonomous system must be able to detect its surroundings, establish its exact location on the road, and decide how to operate in a particular circumstance. As a result, self-driving cars rely heavily on software to bridge the gap between sensor physics and mechanical vehicle actuation, such as steering and brakes.

Perception integrates input from several sensors, such as radars, cameras, and lidars, to create a representation of dynamic objects and static characteristics. The use of filtering and smoothing techniques to precisely compute the current pose of the self-driving car, which represents location and orientation, by comparing the latter to characteristics of a very comprehensive pre-generated map.

The planning component may produce a sequence of intelligent actions based on the vehicle's attitude, the map, and fused object information from perception. It is based on derived situational awareness that takes into consideration the expected conduct of other traffic participants and their possible reciprocal engagement. At each stage, we use the most recent advances in machine learning, such as deep learning.

Several elements make up an autonomous driving system.

Elements of autonomous driving system

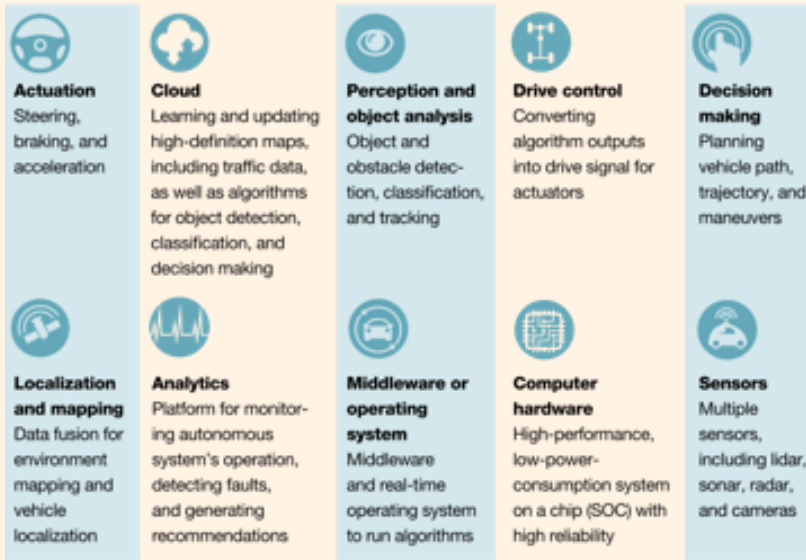

McKinsey&Company

Levels of driving

Level 0: No Automation.

The driver is solely responsible for the vehicle's control.

Level 1: Driver Assistance.

At this stage, the automated systems begin to assume control of the car in particular situations, but not completely. Adaptive cruise control, which manages acceleration and braking in highway driving, is an example of Level 1 automation. Drivers can remove their feet off the pedals depending on the functionality.

Level 2: Partial Automation.

Due to a higher knowledge of its surroundings, the vehicle can execute more complicated operations that combine steering with accelerating and braking.

Level 2+: Advanced Partial Automation.

While Level 2+ is not an officially recognised level, it represents an important category that provides high performance at a reasonable price. Level 2+ duties include those in which the vehicle systems are basically driving, but the driver must still monitor the vehicle and be ready to intervene if necessary.

Level 3: Conditional Automation.

Drivers at Level 3 can withdraw from the act of driving, but only in certain circumstances. Certain vehicle speeds, road types, and weather circumstances may be restricted. This is widely seen as the first step toward autonomous driving.

Level 4: High Automation.

The vehicle's autonomous driving system is fully capable of monitoring the driving environment and performing all driving operations for routine routes and circumstances described within its operational design area at this level.

Level 5: Full Automation.

Vehicles with Level 5 autonomy are completely self-contained. There is no need for a driver at all. Level 5 cars may lack a steering wheel and gas/brake pedals. Level 5 cars may include "smart cabins," allowing passengers to send voice commands to select a destination or set cabin settings such as temperature or media selection.

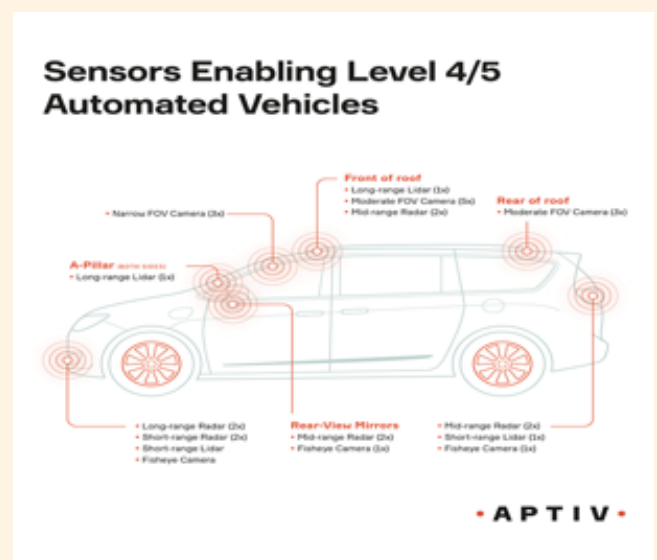

Supercars from the Future

by Yogesh Sigar



We are living in a new age, not at war with each other over petty land but standing together against a common enemy. That is our annihilation. A calamity of our own making. Why? Because our predecessors may very well be fools, dropping nukes, enormous carbon footprint and let's not forget cars. Machines powered by fossil fuels, marauding our climate like nobody else. Some may argue that this is a necessary evil, from burning tons of coal in ancient locomotives to petrol in modern cars. We sure made some advancements, but are we free yet?

No, vehicles remain a major contributor to pollution worldwide.

And here comes Electric vehicles. Tesla, Pravaig, Tata and many more. Almost every car manufacturer is shifting its focus to electric. Why? Because it is the future. But these are all passenger vehicles and where is the fun in that.

Ask a child to draw a car, and he will colour it red" Enzo Ferrari.

Of course, but Ferrari does not make passenger vehicles. So, will the future be without fun, without supercars? Well, I hope not because that would be a shame. But supercar manufactures are not yet thinking about making the future fun, rather than just living in the moment. Like true adventures. So, some new players got on the turf, seeking to get ahead in the race by cutting edge Electric supercars that would even put old fuel-based supercars down it came head-on.

Here I will be putting a few examples to support my claim for the future:

PININFARINA BATTISTA

A name not yet heard, but a with 1877 horsepower. It still sends down a chill through the bones of any car enthusiast. With powertrain provided by the Croatian Rimac. It can go from 0-100 kph in less than 2 seconds. Pininfarina, a brand is known for its work with Ferrari, Rolls- Royce, Alfa Romeo, Cadillac, and Maserati, gives tribute to its founder Battista Pininfarina with this brand new and their first hypercar. Shocked, wait till you hear who owns Pininfarina now. **Mahindra and Mahindra**, yes, an Indian brand now have one of the fastest electric supercars in its fleet.

NIO EP9

Now, why would China leave such a big area unattended, so here comes their gladiator in the arena. **NIO EP9, tuned to track use only, went around Nürburgring in 6 minutes 45.9 seconds.** Unparalleled prowess on the track. With downforce that is double of an F1 car. It sure is made for fun. Also, it made a great presentation in Amazon prime's The grand tour in the hand of Richard Hammond.

RIMAC NEVERA

Saving the absolute beast for the last. Remember Battista, well Rimac is the one who provides the powertrain for that. Numbers can't even properly describe how super this car is but let's see how it fares on paper. 0 – 100 km/h in 1.97 seconds, wait this is a hypercar 100 seems a bit slow so, 0 – 300 km/h in 9.3 seconds. Top speed 412 km/h, 1914 horsepower. Chilling.



**BUT THERE IS ONE THING, ARE ELECTRIC VEHICLES AS CLEAN AS THEY SOUND?
PROBABLY NOT.**

First, the way that electrical energy is harnessed still rely on fossil fuels and other harmful resources. So, we are just adding one more phase into the inevitability.

Second, as the batteries powering these vehicles are mainly based on lead, it's not as recyclable as it sounds. Manufactures such as NIO, have a one-off battery, once finished you will have to replace the whole set and not recharge them. And if caught in an accident, the fires generated from these batteries are not easily extinguished and can keep on burning for days and even weeks. Thus, hurting the environment even more.

While EV's are not as "earth-friendly" as they claim. But they are still a way forward and can be a very sustainable option as soon as the infrastructure of this planet can catch up with the technology that's already there. In the meantime, why not keep our lovely little green ball in mind and have fun with caution. Until Porsche comes up with artificial sustainable gasoline that might even put an end to the electrical era before it even starts. At least that's what they promised.

Featured Article

Fuelling sources and a futuristic approach to depollute

by Ashish and Bhargav

PROPOSED SYSTEM

Charging electrical vehicles (EVs) from electrical phenomenon panels (PV) provides a property future for transportation. This paper presents the event of a 10kW eV the charger which will be steam-powered from each PV array and therefore the three-phase AC grid. The goal is to understand a high power density and high-efficiency three-port power convertor that integrates the eV, PV, grid and meets the Chademo and CCS/Combo eV charging standards. The eV port is meant to be isolated and two-way, so each charging and vehicle-to-Grid (V2G) are often enforced. As PV and eV are each DC naturally, the convertor uses a central DC-link to exchange power between the eV and PV, thereby increasing potency. The employment of carbide devices and powdery alloy core inductors permits high switch frequency and power density. The closed-loop management permits four totally different power flows **PV to EV, EV to the grid, grid to EV and PV to the grid**. thus the convertor operates as a PV electrical converter, a two-way eV charger and a mixture of each.

The event of a high power density, modular, V2G-enabled, integrated power device for charging electrical vehicles from electrical phenomenon panels and therefore the AC grid. Fig. shows the diagram of the three-port device for star charging of work unit with a central DC-link. There are 3 sub-converters inside: a unidirectional DC/DC device for the PV, a bifacial DC/AC {inverter|electrical device} to attach to the AC grid and a bifacial isolated DC/DC converter for the work unit. DC charging of work unit is enforced here as opposition AC charging as Chademo and Combined charging normal (CCS) facilitates good charging, quick charging and V2G. good charging will change the work unit charging to follow the PV generation, energy costs and regulation costs. The developed 3-port design has three blessings. Firstly, since work unit and PV are inherently DC naturally, an indoor DC-link is employed to exchange power between the 3 sub-converters. Secondly, the grid electrical converter is in and of itself bifacial because it must feed PV power to the grid and draw work unit charging power from the grid. Hence, by creating the isolated DC/DC device for work unit bifacial furthermore, V2G operation is enforced. Thirdly, one DC/AC electrical converter is adequate to attach each PV, work unit to the grid. This makes the device cheaper and smaller. Typically, if an associate integrated device isn't used, 2 inverters would be required, one every for PV and work unit.

Schematic Diagram of proposed fast charging station

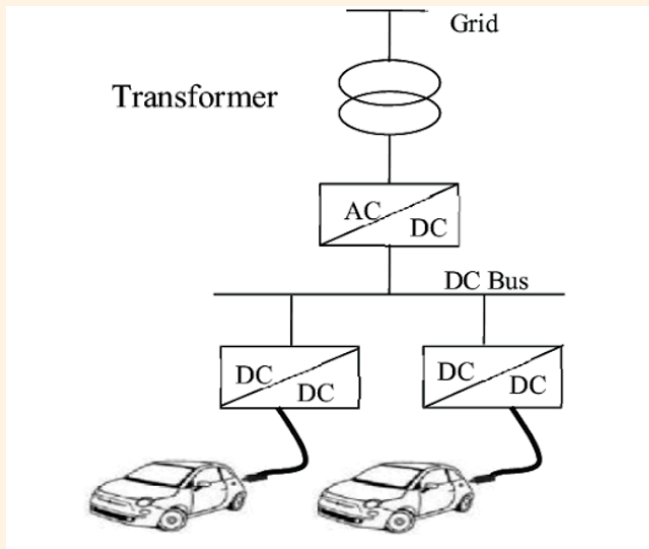

FIGURE 3.1
BLOCK DIAGRAM OF THE GRID CONNECTED BIDIRECTIONAL 10KW THREE-PORT EV-PV CHARGER:

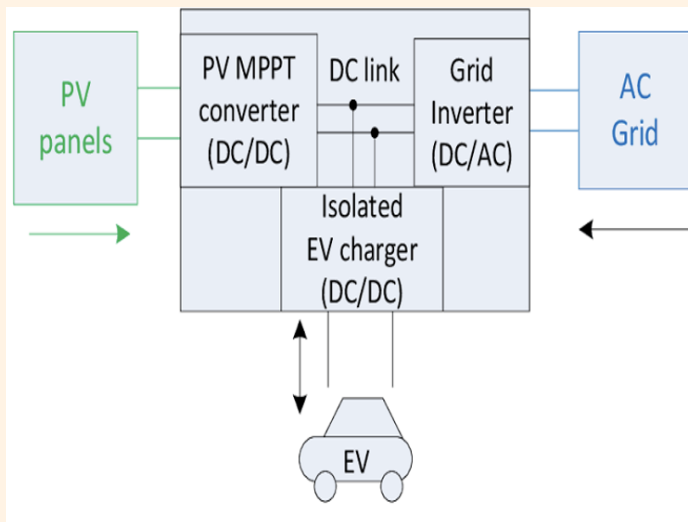

FIGURE 3.2

The crucial aspects of the converter style are achieving high potency, high power density, modularity and low price. The contributions of this work compared to earlier works are as follows:

- Developing a high power biface, isolated, three-port power convertor for direct DC charging of Associate in Nursing electron volt from PV and AC grid. It may be seen from the literature review that such a convertor doesn't presently exist.
- The combined use of attack devices, high switch frequency, interleaving and KoolMμ inductors has resulted within the developed convertor to possess a lot of higher partial and peak load potency and thrice the ability density when put next to existing solutions.

coming up with a closed-loop management that permits four completely different power flows victimization the convertor: PV to EV, PV to Grid, Grid to EV and EV to Grid (i.e., V2G).

- The developed convertor is modularly engineered to be operated either as a DC V2G electron volt charger or as a star supercharged DC V2G electron volt charger. Further, many DC V2G electron volt charger modules may be operated in parallel to proportion the ability from 10kW up to 100kW for quick charging of EVs. progressive star electron volt chargers don't exhibit such high levels of modularity.

- The convertor is intended to be compatible with IEC, Chademo and CCS/Combo DC charging commonplace with reference to ripple, harmonic, voltage vary and isolation needs and charge/V2G operation has been tested employing a Nissan Leaf electron volt. presently developed star electron volt chargers don't meet these criteria for industrial usability.

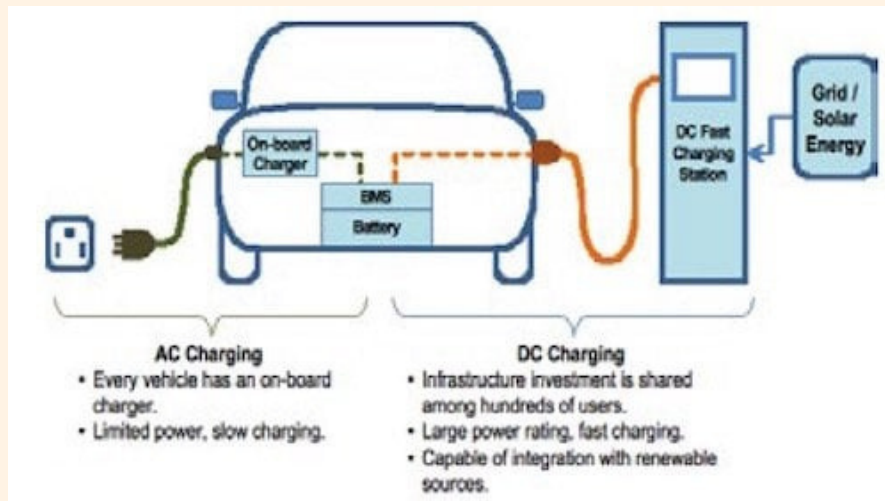

The schematic diagram of planned quick energy unit charging station is shown in Fig. As shown, the given design uses just one AC-DC Grid Tied device to understand a DC bus, connecting the charging EVs through DC-DC converters.

The DC bus makes it possible to attach Renewable Energy Sources (RESs) generation systems directly through a straightforward DC-DC device. it's estimated that DC bus design reduces the conversion losses from regarding thirty second to but 100 percent compared with the AC bus architecture.

3 part provide is taken from grid. 3 phase transformer is utilized to step down the voltage from the distribution grid voltage level to EVs battery voltage levels. 3 part AC/DC device transforms the ac power into dc power and forms a dc bus. EVs connect to the DC bus for charging through DC/DC converters.

A number of aspects have to be compelled to be thought of whereas planning a charging station like

- Available space for parking of electrical vehicles; this determines the quantity of vehicles which may be charged.
- Demand estimation for quick charging slots in an exceedingly explicit space.
- Network constraints like nominal voltage level and permissible power levels at the purpose of common coupling.
- Rate of allowable charging power to be equipped to every vehicle.